

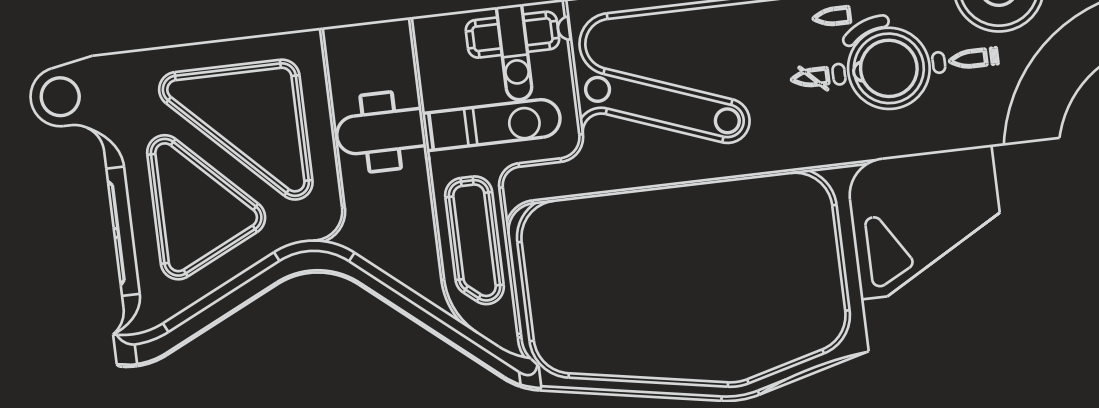

PRODUCT CATALOG - 2019



FIREARMS

# FIREARMS

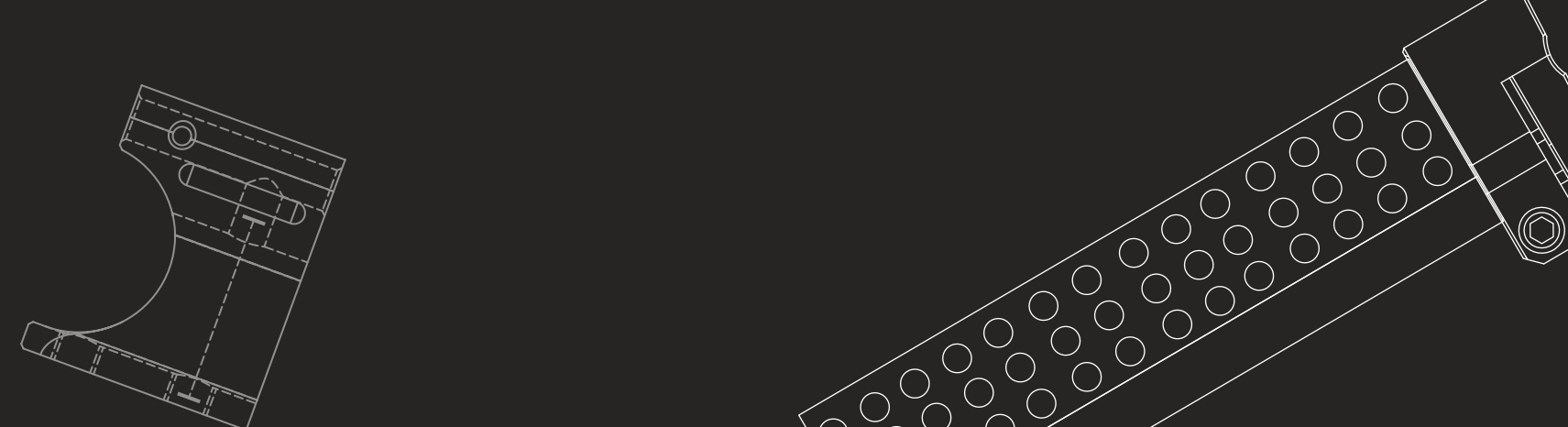

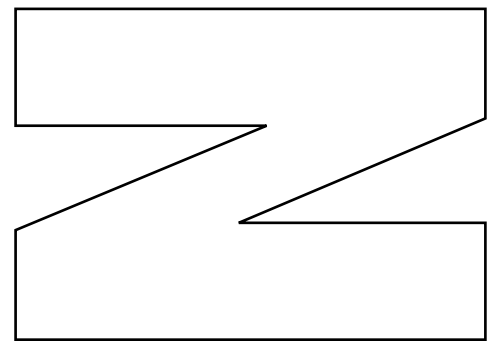
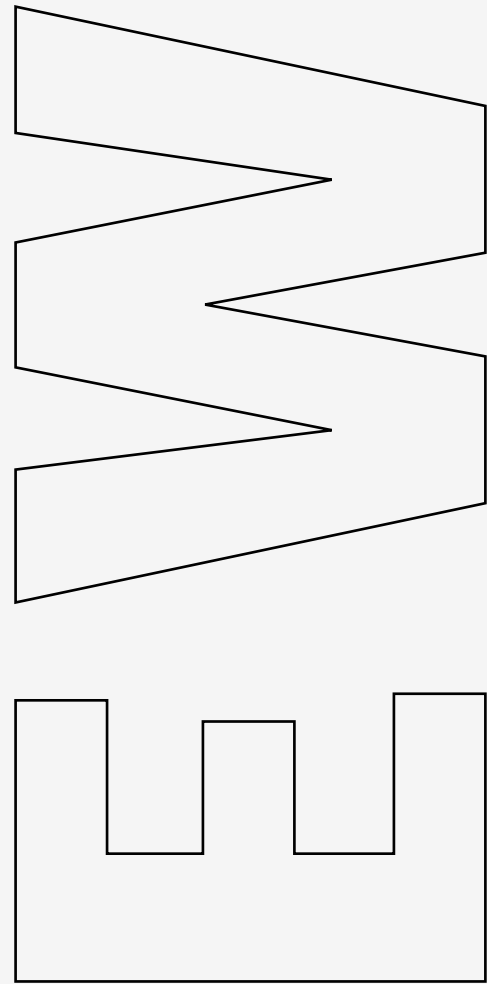

# PRODUCTION RIFLES



- SEMI-AUTO AR STYLE RIFLE
- MODEL: BAD556-LW
- BILLET 7075-T6, 16" 4150 M4 BLACK NITRIDE BARREL
- MFT ADJUSTABLE STOCK
- 5.56 NATO CAL.
- BLACK ANO FINISH
- OPTICS READY

**AUTHORITY™**



# WORKHORSE

- SEMI-AUTO AR STYLE RIFLE
- MODEL BAD-15, FORGED 7075-T6
- 16" 4150 M4 BLACK NITRIDE BARREL
- MFT ADJUSTABLE STOCK, 5.56 NATO CAL. BLACK ANO FINISH
- OPTICS READY



PARATROOPER 7.5"  
.300BLK PDW - SBR

# PARATROOPER 7.5" .300BLK PDW - SBR

\$3,050.00

THE HEART OF THE PARATROOPER IS BUILT ON OUR FAMOUS BAD-PDW MONOLITHIC PDW LOWER RECEIVER & VERT STOCK SYSTEM WITH AMBIDEXTROUS CONTROLS. IT IS CHAMBERED IN .300BLK WITH A 7.5IN BARREL SHROUDED IN 6.7IN RIGIDRAIL M-LOK FREE FLOAT RAIL SYSTEM AND HAS AN OVERALL LENGTH OF 20.1IN. IT IS BUILT AS A FACTORY SBR (SHORT BARREL RIFLE) SO ALL NFA RULES APPLY.

PAYING HOMAGE TO THE OLD-SCHOOL WWII ERA WEAPONS, THE PARATROOPER IS FURNISHED WITH CUSTOM GRADE A FRENCH WALNUT HANDGUARD & PISTOL GRIP. TO CAP IT OFF, IT IS PAIRED WITH WOOD FINISHED SS CHEEK REST (UV STABILIZED, SIMULATED WOOD POWDER COAT FINISH) FOR STRENGTH AND DURABILITY. THE COMPLETE RIFLE IS FINISHED WITH A CUSTOM BLENDED PARKERIZED GREEN STEEL & COSMOLINE THEME FINISH MATCHING THAT OF THE M1 GARAND, M1 CARBINE, 1903A3, ETC.

### SPECS:

- BAD558-LW - BILLET 7075-T6 CNC MACHINED LIGHTWEIGHT UPPER RECEIVER
- BAD-BBL7.5750P3005R1/8N - BATTLEARMS 7.5IN 4150 CM BARREL, TAPERED PROFILE, .750IN DIA. GAS BLOCK JOURNAL, PISTOL LENGTH GAS SYSTEM, .300BLK CAL., 5R RIFLING, 1/8 RIGHT HAND TWIST, BLACK NITRIDE FINISH, DOUBLE STRESS RELIEVED, 5/8X24 THREADED MUZZLE, 11° TARGET CROWN.
- BAD-LGB-TI-750 - TITANIUM GAS BLOCK .750IN DIA.
- ARG7-P-SS - PISTOL LENGTH GAS TUBE - SS
- BAD-EBCG-M16 - ENHANCED BOLT CARRIER GROUP - M16 - BLACK NITRIDE
- 308 A2 COMPENSATOR - 5/8-24 THREAD
- BCM GUNFIGHTER MOD A44 - AMBIDEXTROUS CHARGING HANDLE
- BAD-RR6.7-MLOK - 6.7IN RIGIDRAIL RAIL HANDGUARD - M-LOK
- BAD-PDW - MONOLITHIC PDW LOWER RECEIVER & VERT STOCK SYSTEM WITH AMBIDEXTROUS CONTROLS
- BAD-CASS-SA-ST - COMBAT AMBIDEXTROUS SAFETY SELECTOR - SEMI-AUTO - REVERSIBLE 0°-50° / 0°-90° - STANDARD AND SHORT LEVERS
- BAD-EPS - ENHANCED PIN SET - NITRIDE STEEL
- BAD-EBC-IC - ENHANCED BOLT CATCH, INVESTMENT CAST 8620
- BAD-EMMR-L-B - ENHANCED MODULAR MAGAZINE RELEASE WITH LARGE FINGER PAD
- BAD-WOOD-KIT1 - GRADE A FRENCH WALNUT HANDGUARD & PISTOL GRIP WITH CUSTOM MOUNTING HARDWARE. SIMULATED WOOD SS CHEEK REST.
- MAGPUL MBUS PRO - MAG275 FRONT SIGHT & MAG527 LR ADJUSTABLE REAR SIGHT
- CUSTOM COATING - WWII PARKERIZED GREEN STEEL AND COSMOLINE THEMED FINISH.
- USGI ZORD ALUMINUM MAGAZINES X (2) - CUSTOM LASER ENGRAVED LOGOS
- SBR HARD CASE - BATTLE ARMS DEVELOPMENT SBR HARD CASE WITH CUSTOM HIGH DENSITY FOAM & ACCESSORIES
- TEST FIRE - EACH RIFLE IS INDIVIDUALLY TEST FIRED AT FACTORY TO ENSURE SAFETY AND PROPER FUNCTION





# TANKER 7.5\"/>

\$2,999.99

THE HEART OF THE TANKER IS BUILT ON OUR FAMOUS BAD556-LW BILLET 7075-T6 ALUMINUM LIGHTWEIGHT RECEIVER SET AND THE BAD-CSS VERT PDW STOCK SYSTEM. IT IS CHAMBERED IN .300BLK WITH A 7.5IN BARREL SHROUDED IN 6.7IN RIGIDRAIL M-LOK FREE FLOAT RAIL SYSTEM AND HAS AN OVERALL LENGTH OF 20.1IN. IT IS BUILT AS A FACTORY SBR (SHORT BARREL RIFLE) SO ALL NFA RULES APPLY.

PAYING HOMAGE TO THE OLD-SCHOOL WWII ERA WEAPONS, THE TANKER IS FURNISHED WITH CUSTOM GRADE A FRENCH WALNUT HAND-GUARD & PISTOL GRIP. TO CAP IT OFF, IT IS PAIRED WITH WOOD FINISHED SS CHEEK REST (UV STABILIZED, SIMULATED WOOD POWDER COAT FINISH) FOR STRENGTH AND DURABILITY. THE COMPLETE RIFLE IS FINISHED WITH AN IN-HOUSE CUSTOM BLENDED PARKERIZED GREEN STEEL & COSMOLINE THEME FINISH MATCHING THAT OF THE M1 GARAND, M1 CARBINE, 1903A3, ETC.

## SPECS:

- BAD556-LW-UR - BILLET 7075-T6 CNC MACHINED LIGHTWEIGHT UPPER RECEIVER
- BAD-BBL7.5T750P3005R1/8N - BATTLEARMS 7.5IN 4150 CM BARREL, TAPERED PROFILE, .750IN DIA. GAS BLOCK JOURNAL, PISTOL LENGTH GAS SYSTEM, .300BLK CAL, 5R RIFLING, 1/8 RIGHT HAND TWIST, BLACK NITRIDE FINISH, DOUBLE STRESS RELIEVED, 5/8X24 THREADED MUZZLE, 11° TARGET CROWN.
- BAD-LGB-TI-750 - TITANIUM GAS BLOCK .750IN DIA.
- ARGT-P-SS - PISTOL LENGTH GAS TUBE - SS
- BAD-EBCG-M16 - ENHANCED BOLT CARRIER GROUP - M16 - BLACK NITRIDE
- 30 CAL A2 COMPENSATOR - 5/8-24 THREAD
- AMBIDEXTROUS CHARGING HANDLE
- BAD-RR6.7-MLOK - 6.7IN RIGIDRAIL RAIL HAND-GUARD - M-LOK
- BAD556-LW-LR - BILLET 7075-T6 CNC MACHINED LIGHTWEIGHT LOWER RECEIVER
- BAD-CSS - VERT PDW STOCK SYSTEM
- BAD-CASS-SA-ST - COMBAT AMBIDEXTROUS SAFETY SELECTOR - SEMI-AUTO - REVERSIBLE 0°-50° / 0°-90° - STANDARD AND SHORT LEVERS
- BAD-EPS - ENHANCED PIN SET - NITRIDE STEEL
- BAD-EBC-IC - ENHANCED BOLT CATCH, INVESTMENT CAST 8620
- BAD-EMMR-L-B - ENHANCED MODULAR MAGAZINE RELEASE WITH LARGE FINGER PAD
- BAD-WOOD-KIT1 - GRADE A FRENCH WALNUT HANDGUARD & PISTOL GRIP WITH CUSTOM MOUNTING HARDWARE. SIMULATED WOOD SS CHEEK REST.
- MAGPUL MBUS PRO - MAG275 FRONT SIGHT AND MAG527 LR ADJUSTABLE REAR SIGHT
- CUSTOM COATING - WWII PARKERIZED GREEN STEEL AND COSMOLINE THEMED FINISH.
- USGI 20RD ALUMINUM MAGAZINES X (2) - CUSTOM LASER ENGRAVED LOGOS
- SBR HARD CASE - BATTLE ARMS DEVELOPMENT SBR HARD CASE WITH CUSTOM HIGH-DENSITY FOAM & ACCESSORIES
- TEST FIRE - EACH RIFLE IS INDIVIDUALLY TEST FIRED AT FACTORY TO ENSURE SAFETY AND PROPER FUNCTION



# BATTLEARMS™ TANKER PISTOL

\$ 3,513.00

## TANKER 7.5IN PISTOL

THE HEART OF THE TANKER IS BUILT ON OUR FAMOUS BAD556-LW BILLET 7075-T6 ALUMINUM LIGHTWEIGHT RECEIVER SET AND THE SABERTUBE QD AND TAILHOOK PISTOL BRACE SYSTEM. IT IS CHAMBERED IN .300BLK OR 223WYLDE WITH A 7.5IN BARREL SHROUDED IN 6.7IN RIGIDRAIL M-LOK FREE FLOAT RAIL SYSTEM. IT IS BUILT AS A FACTORY PISTOL. PAYING HOMAGE TO THE OLD-SCHOOL WWII ERA WEAPONS, THE "TANKER" IS FURNISHED WITH CUSTOM GRADE A FRENCH WALNUT HANDGUARD & PISTOL GRIP. THE COMPLETE RIFLE IS FINISHED WITH AN IN-HOUSE CUSTOM BLENDED "PARKERIZED GREEN STEEL & COSMOLINE" THEME FINISH MATCHING THAT OF THE M1 GARAND, M1 CARBINE, 1903A3, ETC.

## SPECS:

### 300BLK

- BAD-BBL7.5T750P3005R1/8N - 7.5IN 4150 CM BARREL, TAPERED PROFILE, .750IN DIA. GAS BLOCK JOURNAL, PISTOL LENGTH GAS SYSTEM, .300BLK CAL., 5R RIFLING, 1/8 RIGHT HAND TWIST, BLACK NITRIDE FINISH, DOUBLE STRESS RELIEVED, 5/8X24 THREADED MUZZLE, 11° TARGET CROWN.
- BAD-LGB-TI-750 - TITANIUM GAS BLOCK .750IN DIA.

### 223WYLDE

- BAD-BBL7.5LR625P223W1/8/SS - 7.5IN LIGHTRIGID 223WYLDE 416R SS .625 DIA GAS BLOCK JOURNAL 1/2X28TPI 1:8T STAINLESS STEEL BARREL
- BAD-LGB-TI-750 - STEEL GAS BLOCK .750IN DIA.
- BAD-LGB-TI-625-B TITANIUM GAS BLOCK .625IN DIA
- BAD556-LW-UR - BILLET 7075-T6 CNC MACHINED LIGHTWEIGHT UPPER RECEIVER
- ARGT-P-SS - PISTOL LENGTH GAS TUBE - SS
- BAD-EBCG-M16 - ENHANCED BOLT CARRIER GROUP - M16 - BLACK NITRIDE
- A2 COMPENSATOR - 5/8-24 THREAD OR 22 CAL A2 COMPENSATOR 1/2X28

- AMBIDEXTROUS CHARGING HANDLE
- BAD-RR6.7-MLOK - 6.7IN RIGIDRAIL RAIL HANDGUARD - M-LOK
- BAD556-LW-LR - BILLET 7075-T6 CNC MACHINED LIGHTWEIGHT LOWER RECEIVER
- SABERTUBE-QD-P-B-COMBO+ GEARHEAD WORKS TAILHOOK PISTOL BRACE SYSTEM
- BAD-CASS-SA-ST - COMBAT AMBIDEXTROUS SAFETY SELECTOR - SEMI-AUTO - REVERSIBLE 0°-50° / 0°-90° - STANDARD AND SHORT LEVERS
- ROCK RIVER NATIONAL MATCH TWO STAGE TRIGGER
- BAD-EPS - ENHANCED PIN SET - NITRIDE STEEL
- BAD-EBC-IC - ENHANCED BOLT CATCH, INVESTMENT CAST 8620
- BAD-EMMR-L-B - ENHANCED MODULAR MAGAZINE RELEASE WITH LARGE FINGER PAD
- BAD-WOOD-KIT1 - GRADE A FRENCH WALNUT HANDGUARD & PISTOL GRIP WITH CUSTOM MOUNTING HARDWARE.
- MAGPUL MBUS PRO - MAG275 FRONT SIGHT AND MAG527 LR ADJUSTABLE REAR SIGHT
- CUSTOM COATING - WWII "PARKERIZED GREEN STEEL AND COSMOLINE" THEMED FINISH.
- USGI 20RD ALUMINUM MAGAZINES X (2) LASER ENGRAVED LOGOS
- HARD CASE - BATTLE ARMS DEVELOPMENT HARD CASE WITH CUSTOM HIGH DENSITY FOAM & ACCESSORIES
- TEST FIRE - EACH RIFLE IS INDIVIDUALLY TEST FIRED AT FACTORY TO ENSURE SAFETY AND PROPER FUNCTION



# WOOD KITS

## MONOLITHIC-PDW

SIMULATED WOOD CHEEK REST | \$50



FRENCH WALNUT WOOD PISTOL GRIP KIT | \$100

## BAD-CSS VERT<sup>®</sup> STOCK SYSTEM

SIMULATED WOOD CHEEK REST | \$50



# THE 300



## THE 300® BLACKOUT

300 BLK PDW (PERSONAL DEFENSE WEAPON)

\$2,499.00  
(WITHOUT SIGHTS)

*THE 300*® is built on Battle Arms Development's Monolithic PDW Lower Receiver and integral VERT™ Stock System for unparalleled strength and weight savings. It features a 7.5" 300 BLK barrel and ambidextrous controls. The ultimate PDW designed with law enforcement, executive protection and special operations in mind. At only 20.1" overall length, *THE 300*® is perfect for where discretion, portability and concealment is of the utmost importance.



## THE BAD 556-LW

BATTLE ARMS DEVELOPMENT, MODEL BAD556-LW



“A BATTLE-READY WORK OF ART.”  
- G. | MILITARY

# BAD556-LW THE 300™ SPARTAN RIFLE

\$3,100.00

BATTLE ARMS DEVELOPMENT, MODEL BAD556-LW - THE 300™ SPARTAN RIFLE

INCLUDES HARD RIFLE CASE WITH CUSTOM FITTED HIGH DENSITY FOAM

OVERALL LENGTH: MIN. 33" TO MAX. 36"  
WEIGHT: 5.7 LBS

CHECK OUT THE 300 SPARTAN INSPIRED CUSTOM THEME CERKOTE PAINT JOB

FORWARD GRIP: FORTIS MFG.  
SHIFT™ SHORT ANGLED GRIP

MAGPUL GEN 2 PMAG WITH MAGPOD™ FLOOR PLATE,  
CERAKOTE FINISH WITH B.A.D INC. LOGO

THE BAD556-LW FEATURES A LIGHTWEIGHT BILLET UPPER RECEIVER IN 7075-T6 AIRCRAFT GRADE ALUMINUM WITH A 16" ULTRAMATCH LIGHTRIGID™ 416R STAINLESS STEEL .223 WYLDE 1:8 TWIST FLUTED LIGHTWEIGHT BARREL. THE BAD-LGB-TI-625 GAS BLOCK IS LIGHTWEIGHT, AND IS MADE OF LOW PROFILE GRADE 5 TITANIUM. THE RIFLE ALSO INCLUDES A MID-LENGTH STAINLESS STEEL GAS TUBE. OTHER FEATURES INCLUDE AN M16 BOLT CARRIER GROUP (BLACK NITRIDE FINISH), A V66 EPSILON COMPENSATOR OR BATTLECOMP MUZZLE DEVICE, A BCMGUNFIGHTER™ AMBI CH OR FORTIS MFG. HAMMER™ CH CHARGING HANDLE, AND A FORTIS MFG. 14" SWITCH™ 556 RAIL SYSTEM. THE BAD556-LW LIGHTWEIGHT BILLET LOWER RECEIVER IN 7075-T6 AIRCRAFT GRADE ALUMINUM, THE BAD-ASS AMBI SAFETY SELECTOR AR15 / AR10®, THE BAD-EPS-TI-B ENHANCED PIN SET - TITANIUM - BLACK IONBOND FINISH, AND CMC TRIGGER 91501 WITH A CURVED SINGLED STAGE TACTICAL 3.5 LB PULL ARE ALSO FEATURED.



# BAD556-LW LIGHTWEIGHT RIFLE VADER THEME INSPIRED

BATTLE ARMS DEVELOPMENT, MODEL BAD556-LW LIGHTWEIGHT RIFLE

\$3,350.<sup>28</sup>

THE BAD556-LW FEATURES A LIGHTWEIGHT BILLET UPPER RECEIVER IN 7075-T6 AIRCRAFT GRADE ALUMINUM WITH A 16" ULTRAMATCH LIGHTRIGID™ 416R STAINLESS STEEL .223 WYLDE 1:8 TWIST FLUTED LIGHTWEIGHT BARREL. THE BAD-LGB-TI-625 GAS BLOCK IS LIGHTWEIGHT, AND IS MADE OF LOW PROFILE GRADE 5 TITANIUM. THE RIFLE ALSO INCLUDES A MID-LENGTH STAINLESS STEEL GAS TUBE. OTHER FEATURES INCLUDE AN M16 BOLT CARRIER GROUP (BLACK NITRIDE FINISH), A V66 EP-SILON COMPENSATOR OR BATTLECOMP MUZZLE DEVICE, A BCMGUNFIGHTER™ AMBI CH OR FORTIS MFG. HAMMER™ CH CHARGING HANDLE, AND A FORTIS MFG. 14" SWITCH™ 556 RAIL SYSTEM. THE BAD556-LW LIGHTWEIGHT BILLET LOWER RECEIVER IN 7075-T6 AIRCRAFT GRADE ALUMINUM, THE BAD-ASS AMBI SAFETY SELECTOR AR15 / AR10®, THE BAD-EPS-TI-B ENHANCED PIN SET - TITANIUM - BLACK IONBOND FINISH, AND CMC TRIGGER 91501 WITH A CURVED SINGLED STAGE TACTICAL 3.5 LB PULL ARE ALSO FEATURED.

### ACCESSORIES

- FORWARD GRIP: FORTIS MFG. SHIFT™ SHORT ANGLED GRIP
- MAGAZINE: MAGPUL GEN 2 PMAG WITH MAGPOD™ FLOOR PLATE, CERAKOTE FINISH WITH B.A.D INC. LOGO
- RIFLE CASE: HARD RIFLE CASE WITH CUSTOM FITTED HIGH DENSITY FOAM
- CERAKOTE: VADER INSPIRED CUSTOM THEME CERKOTE PAINT JOB

### DIMENSIONS

OVERALL LENGTH: 34"  
WEIGHT: 5.4 LBS



# 7.5" 300BLK BAD556-LW PISTOL

\$2,229.<sup>99</sup>

## UPPER

- BAD556-LW-UR LIGHTWEIGHT UPPER RECEIVER
- BAD-BBL7.5T750P3005R1/BBN
- BAD-LGB-TI-750 TITANIUM GAS BLOCK .750IN DIA
- AR-15 PISTOL LENGTH GAS TUBE - SSL
- BAD-EBCG-M16 ENHANCED ANGULAR CUT BCG
- VG6 PRECISION GAMMA 300BLK
- AMBIDEXTROUS CHARGING HANDLE
- BAD-RR6.7-MLOK RIGIDRAIL 6.7IN M-LOK HANDGUARD
- MIL SPEC DUST COVER ASSEMBLY



## LOWER

- BAD556-LW-LR LIGHTWEIGHT LOWER RECEIVER
- BAD-ASS AMBIDEXTROUS SAFETY SELECTOR
- BAD-EPS - ENHANCED PIN SET
- AR-15 SEMI-AUTO FCG POLISHED 4.5-5.5 LBS. PULL
- PISTOL SABERTUBE - TAIL HOOK BRACE COMBO
- CARBINE BUFFER SPRING
- H WEIGHT CARBINE BUFFER
- BAD ATG GRIP 3 POSITION
- BAD-EBC-IC ENHANCED CAST BOLT CATCH
- BAD-EMC-IC ENHANCED CAST MAG CATCH
- BAD-EMR ENHANCED MAGAZINE RELEASE

## ACCESSORIES

- MAGPUL GEN M3 PMAG 300BLK - BATTLEARMS LASER ENGRAVED
- HARD POLYMER - RIFLE CASE - HIGH DENSITY FOAM



# 308 RIFLE / BAD762 KIT + RIGID RAIL



## UPPER RECEIVER SPECIFICATIONS:

- PRECISION CNC FROM BILLET 7075-T6 AEROSPACE ALUMINUM
- PATENTED LIGHTWEIGHT DESIGN
- MACHINED T-MARKS
- MIL-A-8625F, TYPE III, CLASS 2, HARD ANODIZED BLACK FINISH
- COMPATIBLE WITH DPMS PATTERN LOWER RECEIVERS
- ALL COMPONENTS, MATERIAL, AND PACKAGING MADE IN THE USA
- UPPER LOWER COMBINED WEIGHT 200Z



## RIGIDRAIL™ DPMS 308 15" M-LOK HANDGUARD

- PROPRIETARY RIGIDRAIL™ RAIL DESIGN TO BALANCE BETWEEN LIGHT WEIGHT AND STRENGTH/RIGIDITY
- DPMS HIGH PROFILE
- PARTIAL PICATINNY TOP RAIL (MATCHING BAD762 LIGHTWEIGHT UPPER RECEIVER)
- MATERIAL: AIRCRAFT GRADE 6061-T6 ALUMINUM
- OVERALL LENGTH: 15IN
- INNER DIAMETER: 1.43IN
- MAXIMUM SUPPRESSOR INTERNAL: 1.1875IN
- M-LOK SLOTS AT 3, 6, 9, AND PARTIAL 12 O'CLOCK POSITIONS
- ADDITIONAL SINGLE M-LOK SLOTS AT (4) 45° POSITIONS FOR FORWARD MOUNTING OF ACCESSORIES, LIGHT, LASER, ETC.
- BARREL NUT DIAMETER:
- BARREL NUT: 7075 ALUMINUM TYPE 3 CLASS 2 HARD ANODIZED CLEAR (BRONZE FINISH)
- BARREL NUT WRENCH INCLUDED
- NO BARREL NUT SHIMS REQUIRED FOR INSTALLATION
- 17-4PH CORED STAINLESS STEEL RAIL MOUNTING ATTACHMENT - PATENT PENDING BY CMT
- (4) ANTI ROTATION QD SLING SOCKETS: (2) AT THE FRONT AND (2) AT THE REAR. 3 & 9 O'CLOCK POSITIONS
- NO CONTACT WITH GAS TUBE
- COMPATIBLE WITH MOST LOW PROFILE GAS BLOCKS
- WEIGHT: 13.70Z WITH HARDWARE
- ROTATION LIMITED QD SOCKETS

## LOWER RECEIVER SPECIFICATIONS:

- PRECISION CNC FROM BILLET 7075-T6 AEROSPACE ALUMINUM
- DPMS HIGH PROFILE
- PATENTED LIGHTWEIGHT DESIGN
- HIGH PRECISION WIRE EDM CNC MAG WELL
- MIL-A-8625F, TYPE III, CLASS 2, HARD ANODIZED BLACK FINISH
- COMPATIBLE WITH DPMS 308 LOWER PART KITS
- PROPRIETARY AMBIDEXTERIOUS MAGAZINE AND BOLT RELEASE (INCLUDED)
- DIMENSIONAL ACCURACY INSPECTION
- ALL SHARP EDGES DE-BURRED SHARP BY HAND
- PICTOGRAPH SELECTOR MARKINGS PROPERLY MARKED FOR 90° SAFETY OR BAD-ASS-ST / BAD-CASS-ST SHORT THROW AMBIDEXTROUS SAFETY SELECTORS
- RECEIVER SAFETY SELECTOR HOLE & INTERNAL WALL MACHINED WITH RELIEF CUT FOR BATTLE ARMS DEVELOPMENT "SHORT-THROW / REVERSIBLE" AMBIDEXTROUS SAFETY SELECTORS (BAD-ASS-ST AND BAD-CASS-SA-ST)
- MULTI CALIBER MARKING FOR BUILD VERSATILITY
- FLARED, DEEP BEVELED MAGWELL
- EASY IN INSTALL SET SCREW BOLT CATCH PIN (PIN INCLUDED)
- CAPTURED TAKEDOWN PIN DETENT SPRING (SET SCREW INCLUDED)
- UPPER/LOWER RECEIVER TENSION SCREW (SCREW INCLUDED)
- INTEGRATED TRIGGER GUARD



# 16" 300BLK BAD556-LW RIFLE

\$2,400.00



## UPPER

- BAD556-LW-UR LIGHTWEIGHT UPPER RECEIVER
- BAD-BBL16T750P3005R1/BBN
- BAD-LGB-TI-750 TITANIUM GAS BLOCK .750IN DIA
- AR-15 CARBINE LENGTH GAS TUBE - SSL
- BAD-EBCG-M16 BCG
- A2 COMP 300BLK
- STRIKE INDUSTRIES ARCH CHARGING HANDLE
- BAD-RR15-MLOK RIGIDRAIL 15IN M-LOK HANDGUARD
- MIL SPEC DUST COVER ASSEMBLY

## ACCESSORIES

- MAGPUL GEN M2 PMAG - BATTLEARMS LASER ENGRAVED
- HARD POLYMER - RIFLE CASE - HIGH DENSITY FOAM

## LOWER

- BAD556-LW-LR LIGHTWEIGHT LOWER RECEIVER
- BAD-ASS AMBIDEXTROUS SAFETY SELECTOR
- BAD-EPS - ENHANCED PIN SET
- CMC FLAT 3.5 SINGLE STAGE TRIGGER
- MIDLENGTH SABERTUBE - LIGHTWEIGHT BUTT STOCK COMBO
- CARBINE BUFFER SPRING
- CARBINE BUFFER
- BAD ATG GRIP 3 POSITION
- BAD-EBC ENHANCED BOLT CATCH CNC
- MILSPEC MAG CATCH
- BAD-EMR ENHANCED MAGAZINE RELEASE





# 9MM PCC BLK RIFLE

# 9MM PCC



BOLT ACTION RIFLES



# BAD-DBM | \$285.00

REMINGTON M700SA (SHORT ACTION) DETACHABLE BOX MAGAZINE BOTTOM METAL WITH PATENTED AMBIDEXTROUS MAGAZINE RELEASE (INTEGRAL TO TRIGGER GUARD)

USE: AICS 5RD (#3901) AND 10RD (#3902) DOUBLE STACKED, SHORT ACTION, 308 MAGAZINES (MAGAZINES NOT INCLUDED)



# BAD RIFLE STAND

## BAD BILLET AR DISPLAY STAND - BAD-AR515

- 6061-T6 ALUMINUM BILLET
- FOUR MOUNTING HOLES ON BOTTOM 1/4X28 TPI
- POCKETED THROUGH HOLE FOR CABLE LOCK
- CAN ADD CUSTOM ENGRAVING!!
- RAW MACHINING ALUMINUM FINISH
- CUSTOM COLORS AVAILABLE
- CAN BE CUSTOM ENGRAVED WITH LOGOS OR TEXT. CONTACT FOR YOUR CUSTOM QUOTE.

\$ 69.<sup>95</sup>

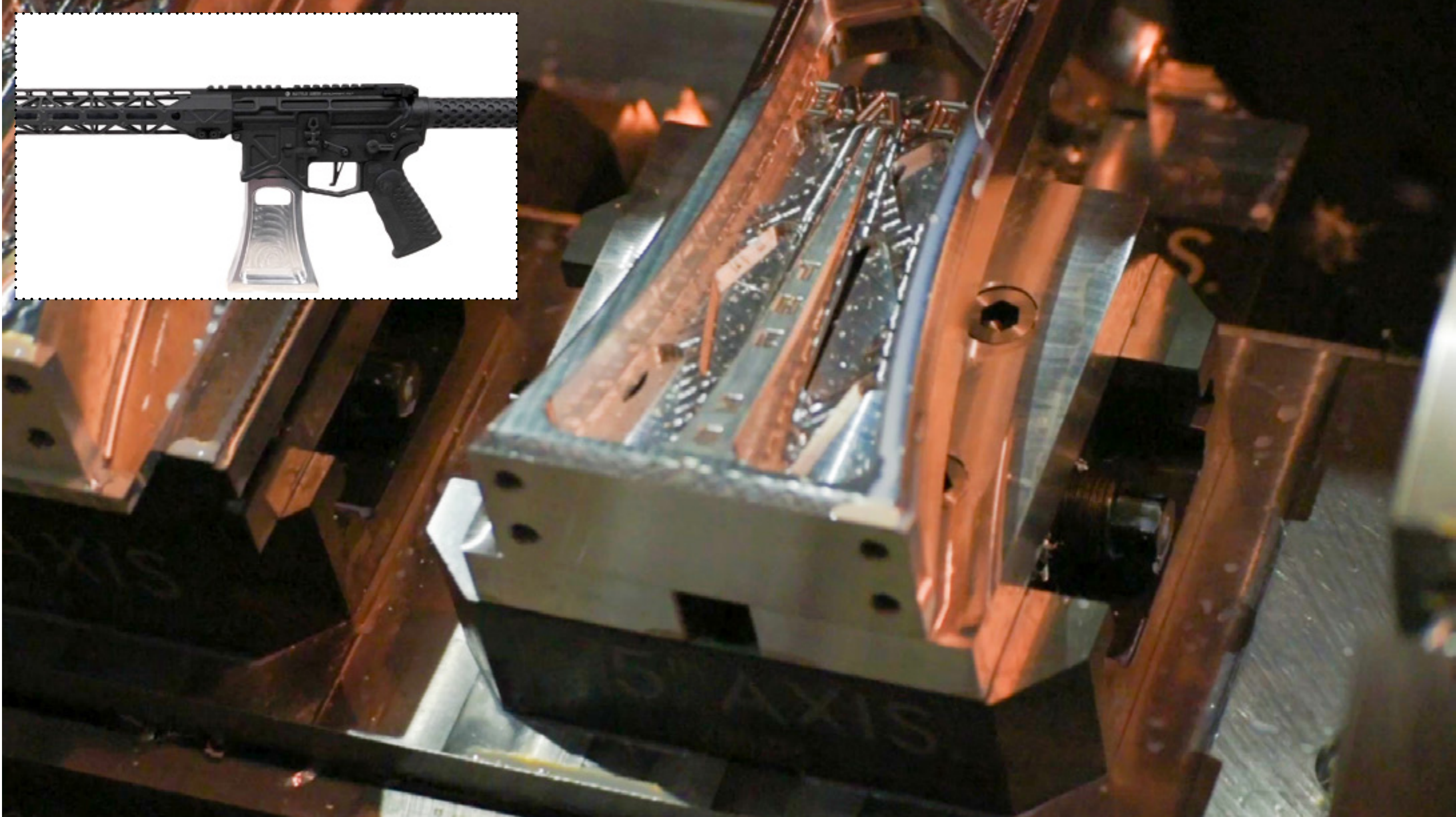



# UN12 MAGAZINE

## NEW PRODUCTS

**BATTLEARMSTM' OIP<sup>®</sup> GEN 2**
**\$3,229.00**

THE RIFLE THAT STARTED THE LIGHTWEIGHT TREND IN THE AR INDUSTRY IS BACK AND BETTER THAN EVER! AFTER A "NO COMPROMISES" UPGRADE, BATTLEARMSTM' OIP<sup>®</sup> ULTRALIGHT RIFLE OTHERWISE KNOWN AS "OUNCES IS POUNDS".

THE DESIGN TAKES LIGHTWEIGHT TO NEW HEIGHTS WITH VIRTUALLY ALL CUSTOM BATTLEARMSTM COMPONENTS. AEROSPACE GRADE CARBON FIBER HANDGUARD, TITANIUM BCG WITH AR-MORTITM COATING, TITANIUM BILLET BOLT CATCH, TITANIUM THUMPERTM MUZZLE BRAKE, PATENTED OIP<sup>®</sup> BUFFER & STOCK SYSTEM AND STRUCTURALLY ENGINEERED LIGHTWEIGHT 7075-T6 BILLET ALUMINUM RECEIVERS ARE AMONG SOME OF THE BATTLEARMSTM LIGHTWEIGHT COMPONENTS THAT MAKE UP THE OIP<sup>®</sup> ULTRALIGHT RIFLE.

- LIMITED RUN OF 11 WITH DIMPLED BARREL!
- THESE WILL NEVER BE OFFERED LIKE THIS AGAIN!
- DIMPLED BARREL BRINGS THIS TO 4LB RIFLE.
- 14.5IN PINNED WELDED BARREL NO NFA TAX STAMP REQUIRED.
- MATCH GRADE 2 STAGE TRIGGER

**OIP<sup>®</sup>**  
 (OUNCES IS POUNDS)  
**ULTRALIGHT  
 RIFLE**



# BATTLEARMS RACK™

\$125.00

- TRULY ORIGINAL
- THE REVOLUTIONARY NEW MECHANISM IS UNLIKE ANY OTHER CHARGING HANDLE ON THE MARKET.
- WE ARE PLEASED TO RECEIVE U.S. UTILITY PATENT NO. 9964371, 9810494, 9587896.
- NO WEAK ROLL PINS
- EVEN THE BEST-DESIGNED PRODUCTS FAIL AT THEIR WEAKEST POINT AND WE HAVE TAKEN THE INFAMOUS ROLL PINS OUT OF THE EQUATION. THE RACK™ WAS DESIGNED WITH NO ROLL PINS.
- SMOOTH SLIDING LATCH
- NOT ANOTHER PIVOTING MECHANISM TO WEAR OUT THE UPPER RECEIVER NOTCH, THIS PATENTED LATCH SYSTEM SLIDES PARALLEL WITH THE RECEIVER NOTCH FOR SLICK AND QUICK RELEASE AND SIMULTANEOUSLY MINIMIZES WEAR.
- ASYMMETRIC CHARGING
- PURPOSE BUILT WITH ASYMMETRIC USE IN MIND, THE RACK™ WILL HANDLE LEFT OR RIGHT SIDE PULLS WITH EASE. REGARDLESS OF YOUR CHARGING HANDLE RACKING TECHNIQUE, THE RACK™ WILL PERFORM WITH CONSISTENT AND POSITIVE ASSURANCE.
- MONOLITHIC MODULAR HANDLE
- MACHINED FROM ONE SINGLE PIECE OF ALUMINUM, THE RACK™ HANDLE WAS DESIGNED WITH STRENGTH IN MIND.
- IT IS ALSO KEY TO THE SLIDING LATCH AND THE POSITIVE AND BALANCED PULL OF THE CHARGING HANDLE.
- MADE IN THE USA
- THE RACK™ IS DESIGNED AND ENGINEERED IN THE UNITED STATES.
- IT IS PRECISION CNC MACHINED FROM BILLET 7075 T6 AIRCRAFT GRADE ALUMINUM IN OUR BRAND-NEW MANUFACTURING FACILITY IN HENDERSON, NEVADA.
- COATED IN A HARD ANODIZED BLACK FINISH.



# RACK™

# TANKER 7.5" .300BLK PDW - SBR

\$2,999.99

THE HEART OF THE TANKER IS BUILT ON OUR FAMOUS BAD556-LW BILLET 7075-T6 ALUMINUM LIGHTWEIGHT RECEIVER SET AND THE BAD-CSS VERT PDW STOCK SYSTEM. IT IS CHAMBERED IN .300BLK WITH A 7.5IN BARREL SHROUDED IN 6.7IN RIGIDRAIL M-LOK FREE FLOAT RAIL SYSTEM AND HAS AN OVERALL LENGTH OF 20.1IN. IT IS BUILT AS A FACTORY SBR (SHORT BARREL RIFLE) SO ALL NFA RULES APPLY.

PAYING HOMAGE TO THE OLD-SCHOOL WWII ERA WEAPONS, THE TANKER IS FURNISHED WITH CUSTOM GRADE A FRENCH WALNUT HAND-GUARD & PISTOL GRIP. TO CAP IT OFF, IT IS PAIRED WITH WOOD FINISHED SS CHEEK REST (UV STABILIZED, SIMULATED WOOD POWDER COAT FINISH) FOR STRENGTH AND DURABILITY. THE COMPLETE RIFLE IS FINISHED WITH AN IN-HOUSE CUSTOM BLENDED PARKERIZED GREEN STEEL & COSMOLINE THEME FINISH MATCHING THAT OF THE M1 GARAND, M1 CARBINE, 1903A3, ETC.



# WW II



# SAFETY SELECTORS



# BAD-ASS

AMBIDEXTROUS SAFETY SELECTOR (BAD-ASS) FOR THE AR15 STYLE RIFLES AND THE ARMALITE, INC.'S AR10® (SEMI AUTO). THE LEVERS ARE DETACHABLE AND INTERCHANGEABLE ON BOTH SIDES FOR MAXIMUM FLEXIBILITY AND USER PREFERENCE. THERE ARE A TOTAL OF (9) LEVER DESIGNS AND (81) POSSIBLE LEVER COMBINATIONS! THE BAD-ASS IS A MUST HAVE FOR THE "SOUTH PAW" AND AMBI-DEXTROUS SHOOTERS!

## THE ANCESTRY OF THE BAD-ASS & BAD-CASS



### WHAT'S THE DIFFERENCE?

# VS



# BAD-CASS

WHAT IS DIFFERENT WITH THE BAD-CASS FAMILY OF SAFETY SELECTORS VS. THE ORIGINAL BAD-ASS FAMILY OF SAFETY SELECTORS ARE THE WAY THE LEVERS ARE ATTACHED. THE DOVETAIL LEVER ATTACHMENT OF THE BAD-CASS ALLOWS FOR SUPERIOR STRENGTH AND DEPENDABILITY BY REMOVING THE STRESS FROM THE SCREWS. ORIGINALLY DESIGNED FOR MILITARY APPLICATIONS, THE BAD-CASS COMBAT AMBIDEXTROUS SAFETY SELECTOR IS NOW AVAILABLE TO ALL.

**"I CAN'T THINK OF A SINGLE REASON NOT TO BUY THIS SAFETY."**  
- THE TRUTH ABOUT GUNS.COM





# OPTIONS FOR

# EVERY SHOOTER



WELCOME TO OUR BAD-ASS  
(AND CASS) FAMILY

- BAD-ASS** AMBI SAFETY SELECTOR  
AR15 / AR10®
- BAD-ASS-ST** SHORT THROW AMBI SAFETY SELECTOR  
AR15 / AR10®
- BAD-ASS-LW** AMBI LIGHTWEIGHT SAFETY SELECTOR  
AR15 / AR10®
- BAD-ASS-MP15-22** AMBI SAFETY SELECTOR  
FOR THE SMITH & WESSON MP15-22 RIFLE

- BAD-CASS-SA** COMBAT AMBI SAFETY SELECTOR • SEMI AUTOMATIC  
AR15 / AR10®
- BAD-CASS-SA-ST** COMBAT SHORT THROW AMBI SAFETY SELECTOR • SEMI AUTOMATIC  
AR15 / AR10®
- BAD-CASS-FA** COMBAT AMBI SAFETY SELECTOR • FULL AUTOMATIC  
M16/ M4

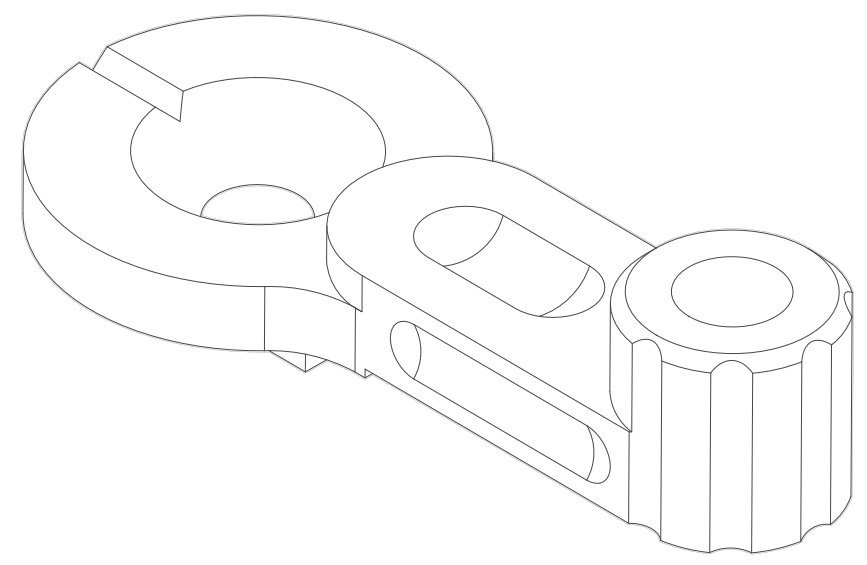



## BAD-ASS-LW

AMBI SAFETY SELECTOR  
AR15 / AR10®

**\$65**

FEATURING A LIGHTWEIGHT SKELETONIZED CENTER/  
CORE AND LIGHTWEIGHT BILLET 7075-T6 ALUMINUM  
SKELETONIZED STANDARD AND SHORT LEVERS. ONLY  
0.42 OZ.

\*LEVERS ARE NOT INTERCHANGIBLE AND ARE SOLD WITH A STANDARD AND SHORT CONFIGURATION ONLY.



## BAD-ASS-MP15-22

SHORT THROW AMBI SAFETY SELECTOR  
SMITH & WESSON MP15-22

**\$54** AND UP

DESIGNED FOR THE SMITH & WESSON  
M&P15-22 RIFLE ONLY.



**BAD-ASS-LW**  
ONLY **0.42 OZ**

MORE THAN 81 POSSIBLE LEVER COMBINATIONS!



# HOME OF THE ORIGINAL BAD-ASS

OUR BAD-ASS SAFETY SELECTORS ARE AMBIDEXTROUS, AVAILABLE IN A 90° OR 45° THROW, COME WITH A VARIETY OF LEVER AND COLOR OPTIONS, AND CAN GET EVEN LIGHTER IN WEIGHT WITH OUR SKELETONIZED LEVERS.

## BAD-ASS

AMBI SAFETY SELECTOR  
AR15 / AR10®

\$60 AND UP

- EACH RETAIL PACKAGE COMES WITH:
- (1) SAFETY CENTER (0°-90° SEMI AUTO)
  - (2) LEVERS - BLACK PHOSPHATE
  - (2) TORX SCREWS BLACK OXIDE
  - (1) HARDENED STAINLESS STEEL SAFETY DETENT (BY KNS PRECISION)
  - (1) T10 TORX L-KEY
  - (1) SELECTOR DETENT SPRING
- PRECISION CNC MACHINED FROM BAR STOCK STEEL



## BAD-ASS-ST

SHORT THROW AMBI SAFETY SELECTOR  
AR15 / AR10®

\$85 AND UP

- EACH RETAIL PACKAGE COMES WITH:
- (1) SAFETY CENTER (0°-90° SEMI AUTO)
  - (2) LEVERS - BLACK PHOSPHATE
  - (2) TORX SCREWS BLACK OXIDE
  - (1) HARDENED STAINLESS STEEL SAFETY DETENT (BY KNS PRECISION)
  - (1) T10 TORX L-KEY
  - (1) SELECTOR DETENT SPRING
- PRECISION CNC MACHINED FROM BAR STOCK STEEL



## BAD-E4S-IC

ENHANCED SINGLE SIDE SAFETY SELECTOR

BAD-E4S ENHANCED SINGLE SIDED SAFETY SELECTOR FOR THE AR15 STYLE RIFLES AND THE ARMALITE, INC.'S AR10® (SEMI AUTO).

\$16



- BASED ON OUR FAMOUS BAD-ASS AMBIDEXTROUS SAFETY SELECTOR WITH DISTINCTIVE AND DIAGONAL SERRATIONS.
- AR15 STYLE RIFLES AND THE ARMALITE, INC.'S AR10® (SEMI AUTO).
- SINGLE SIDE SAFETY SELECTOR (0°-90° SEMI AUTO)
- FIT ALL MIL-SPEC DIMENSIONED AR-15 LOWER RECEIVER
- BLACK PHOSPHATE FINISH
- INVESTMENT CAST 8620 HEAT TREATED STEEL

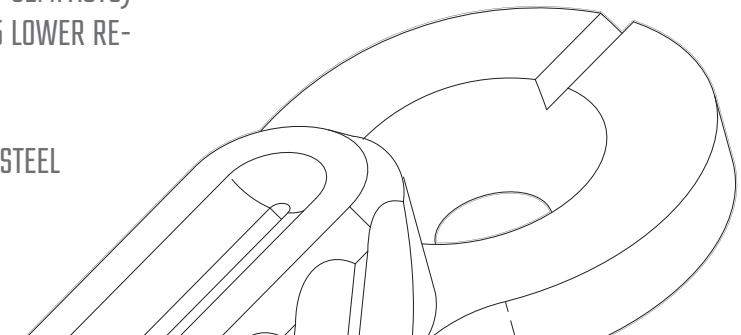

# THE BAD-CASS LINEUP

OUR BAD-CASS COMBAT SAFETY SELECTORS REMAIN AMBIDEXTROUS, AND ARE AVAILABLE IN THREE VARIATIONS: 90° SEMI AUTOMATIC, REVERSIBLE 50°/90° SHORT THROW, AND 90° FULL AUTOMATIC. WE, OF COURSE, STILL GIVE SHOOTERS 9 LEVERS TO CHOOSE FROM.



## BAD-CASS-SA

COMBAT AMBI SAFETY SELECTOR

AR15 / AR10®

\$70 AND UP

DESIGNED FOR AR15 STYLE RIFLES AND ARMALITE, INC.'S SEMI AUTOMATIC AR10®. THE LEVERS ARE DETACHABLE AND INTERCHANGEABLE ON BOTH SIDES FOR MAXIMUM FLEXIBILITY AND USER PREFERENCE.



## BAD-CASS-FA

COMBAT AMBI SAFETY SELECTOR - FULL AUTO  
M16 / M4®

\$99 AND UP

DESIGNED FOR THE SELECT FIRE, M16 / M4 STYLE RIFLES.



## BAD-CASS-SA-ST

COMBAT SHORT THROW AMBI SAFETY SELECTOR  
AR15 / AR10®

\$95 AND UP

DESIGNED FOR THE SELECT FIRE, M16 / M4 STYLE RIFLES.



# DEVELOPED TO MEET THE HIGH STANDARDS SET FORTH BY THE MILITARY



**BAD-ASS-SSL**  
**AMBI SAFETY SELECTOR**  
STAINLESS STEEL  
AR15 / AR10®  
**\$79** AND UP



**BAD-ASS-FDE**  
**AMBI SAFETY SELECTOR**  
CERAKOTE MAGPUL FDE  
AR15 / AR10®  
**\$79** AND UP



**BAD-ASS-SWR**  
**AMBI SAFETY SELECTOR**  
CERAKOTE SMITH & WESSON RED  
AR15 / AR10®  
**\$79** AND UP

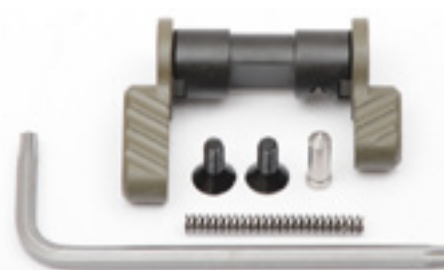

**BAD-ASS-OD**  
**AMBI SAFETY SELECTOR**  
CERAKOTE MAGPUL OD GREEN  
AR15 / AR10®  
**\$79** AND UP

## SPRINGS / SCREWS / SINGLE LEVERS



AR15 / M16 EJECTOR / SAFETY  
SELECTOR DETENT SPRING

\$0.50



4-40 X 3/8" 1-10  
FLAT HEAD CAP SCREW  
FOR BAD-ASS/CASS  
2PK - BLACK OXIDE  
\$1.00



AR15/M16  
SAFETY SELECTOR DETENT  
HEAT TREATED STAINLESS STEEL  
\$1.50



BONHUS T10 L-WRENCH  
COMPATIBLE WITH BAD-ASS &  
BAD-CASS AMBIDEXTROUS SAFETY  
SELECTOR SCREWS.  
\$1.75



BAD-ASS LEVER OPTIONS  
- BLACK PHOSPHATE

STANDARD: \$17.95  
SHORT: \$17.95  
THIN: \$17.95  
SHORT+THIN: \$17.95  
HYBRID: \$23.95  
CRANK: \$23.95  
SHORT CRANK: \$23.95  
SCALLOP: \$23.95  
END CAP: \$15.00



BAD-ASS CERAKOTE  
- MAGPUL OD GREEN

STANDARD: \$26.95  
SHORT: \$26.95  
THIN: \$26.95  
SHORT+THIN: \$26.95  
HYBRID: \$32.95  
CRANK: \$32.95  
SHORT CRANK: \$32.95  
SCALLOP: \$32.95



BAD-ASS CERAKOTE  
- MAGPUL FDE

STANDARD: \$26.95  
SHORT: \$26.95  
THIN: \$26.95  
SHORT+THIN: \$26.95  
HYBRID: \$32.95  
CRANK: \$32.95  
SHORT CRANK: \$32.95  
SCALLOP: \$32.95



BAD-ASS  
- STAINLESS STEEL

STANDARD: \$29.00  
SHORT: \$29.00  
THIN: \$29.00  
SHORT+THIN: \$29.00  
HYBRID: \$35.00  
CRANK: \$35.00  
SHORT CRANK: \$35.00  
SHORT CRANK: \$35.00  
SCALLOP: \$26.00



BAD-CASS LEVER OPTIONS  
- BLACK PHOSPHATE

STANDARD: \$25.95  
SHORT: \$25.95  
THIN: \$25.95  
SHORT+THIN: \$25.95  
END CAP: \$17.95



BAD-ASS-CENTER 90 DEGREE  
-CENTER ONLY  
\$25.95



BAD-ASS-CENTER FOR  
MP15-22. 90 DEGREE  
-CENTER ONLY  
-FOR MP15-22 RECEIVERS ONLY  
WILL NOT FIT STANDARD AR15/AR10 RECEIVER  
\$25.95



BAD-CASS SEMI AUTO  
CENTER 90 DEGREE  
-CENTER ONLY  
\$35.15



BAD-ASS-SHORT THROW  
CENTER 50 DEGREE  
-CENTER ONLY  
-SHORT THROW COMPATIBLE  
LOWER RECEIVERS ONLY  
\$39.95



BAD-CASS FULL AUTO  
CENTER 90 DEGREE  
-CENTER ONLY  
\$56.95

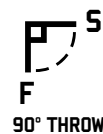
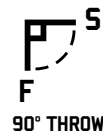

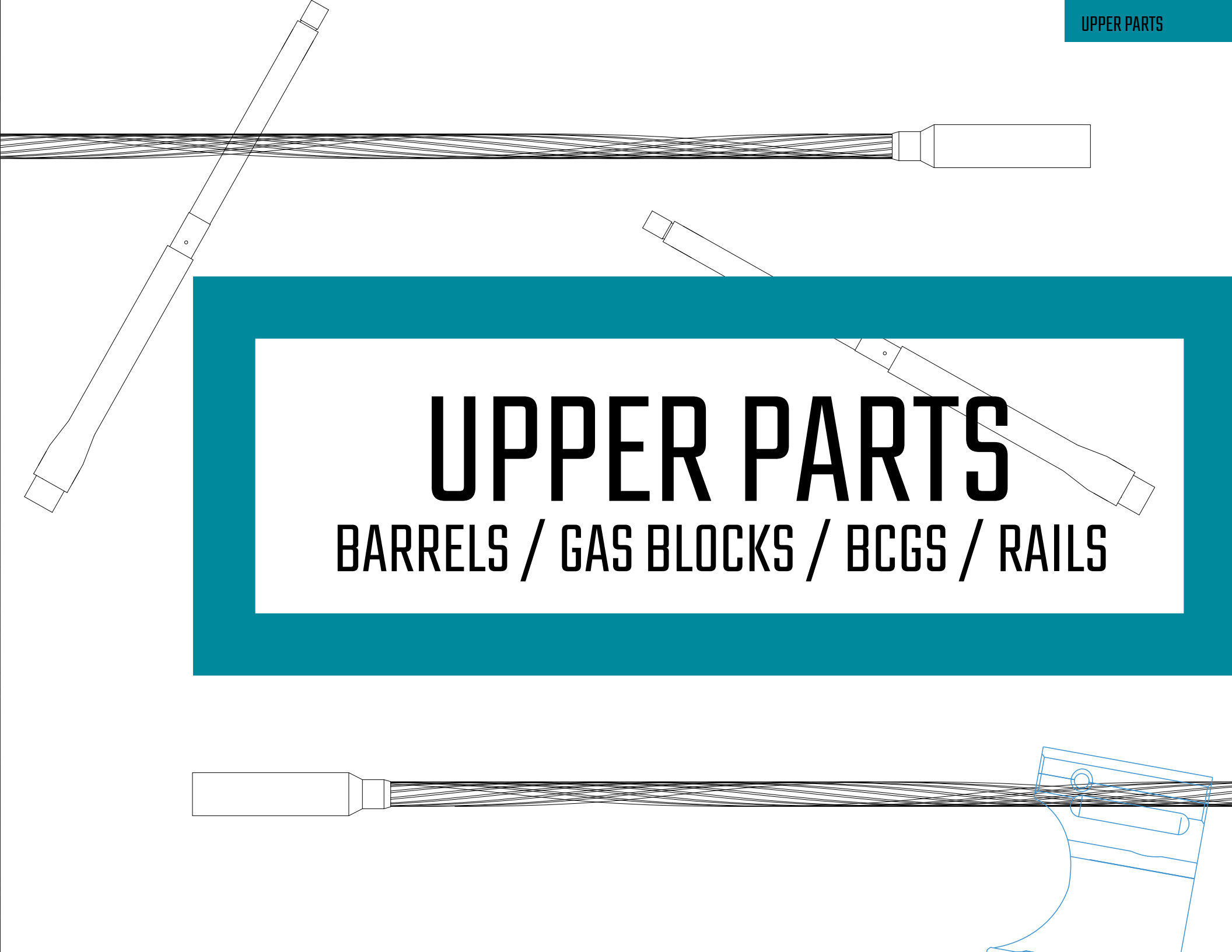

# UPPER PARTS

BARRELS / GAS BLOCKS / BCGS / RAILS

# MEET OUR STAINLESS STEEL FINISH

1:8 TWIST • POLISHED CHAMBER • POLISHED M4 FEED RAMPS • DIMPLED FOR GAS BLOCK SET SCREW • 1/2-28 MUZZLE THREAD • HONED CHAMBER



## ULTRAMATCH RIGID™ 416R SS .223 WYLDE FLUTED LIGHTWEIGHT BARREL

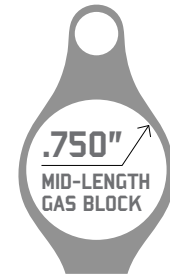

**7.5"** | \$325.00  
PISTOL LENGTH GAS SYSTEM

**10.5"** | \$425.00  
CARBINE LENGTH GAS SYSTEM

**14.5"** | \$515.00  
MID LENGTH GAS SYSTEM

**16"** | \$515.00  
MID LENGTH GAS SYSTEM

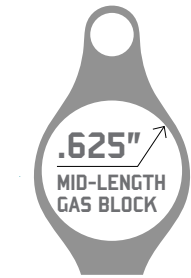

## ULTRAMATCH LIGHTRIGID™ 416R SS .223 WYLDE FLUTED LIGHTWEIGHT BARREL

**7.5"** | \$325.00  
PISTOL LENGTH GAS SYSTEM

**10.5"** | \$425.00  
CARBINE LENGTH GAS SYSTEM

**14.5"** | \$515.00  
MID LENGTH GAS SYSTEM

**16"** | \$515.00  
MID LENGTH GAS SYSTEM  
ONLY 24.60Z





# MEET OUR BLACK CONTRAST FINISH

1:8 TWIST • POLISHED CHAMBER • POLISHED M4 FEED RAMPS • DIMPLED FOR GAS BLOCK SET SCREW • 1/2-28 MUZZLE THREAD • HONED

## ULTRAMATCH RIGID™ 416R SS .223 WYLDE FLUTED LIGHTWEIGHT BARREL

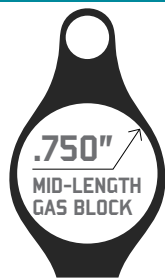

**7.5"** | \$360.00  
PISTOL LENGTH GAS SYSTEM

**10.5"** | \$465.00  
CARBINE LENGTH GAS SYSTEM

**14.5"** | \$555.00  
MID LENGTH GAS SYSTEM

**16"** | \$555.00  
MID LENGTH GAS SYSTEM

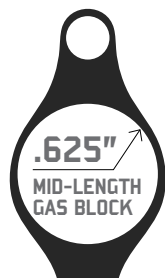

## ULTRAMATCH LIGHTRIGID™ 416R SS .223 WYLDE FLUTED LIGHTWEIGHT BARREL

**7.5"** | \$360.00  
PISTOL LENGTH GAS SYSTEM

**10.5"** | \$465.00  
CARBINE LENGTH GAS SYSTEM

**14.5"** | \$555.00  
MID LENGTH GAS SYSTEM

**16"** | \$555.00  
MID LENGTH GAS SYSTEM  
ONLY 24.60Z



# BLACK CONTRAST FINISH



# BAD-BBLG19BNFT GLOCK G19 BARREL

4140 BLACK NITRIDE OR CLEAR WITH THREADED AND NON THREADED OPTIONS

\$219.00

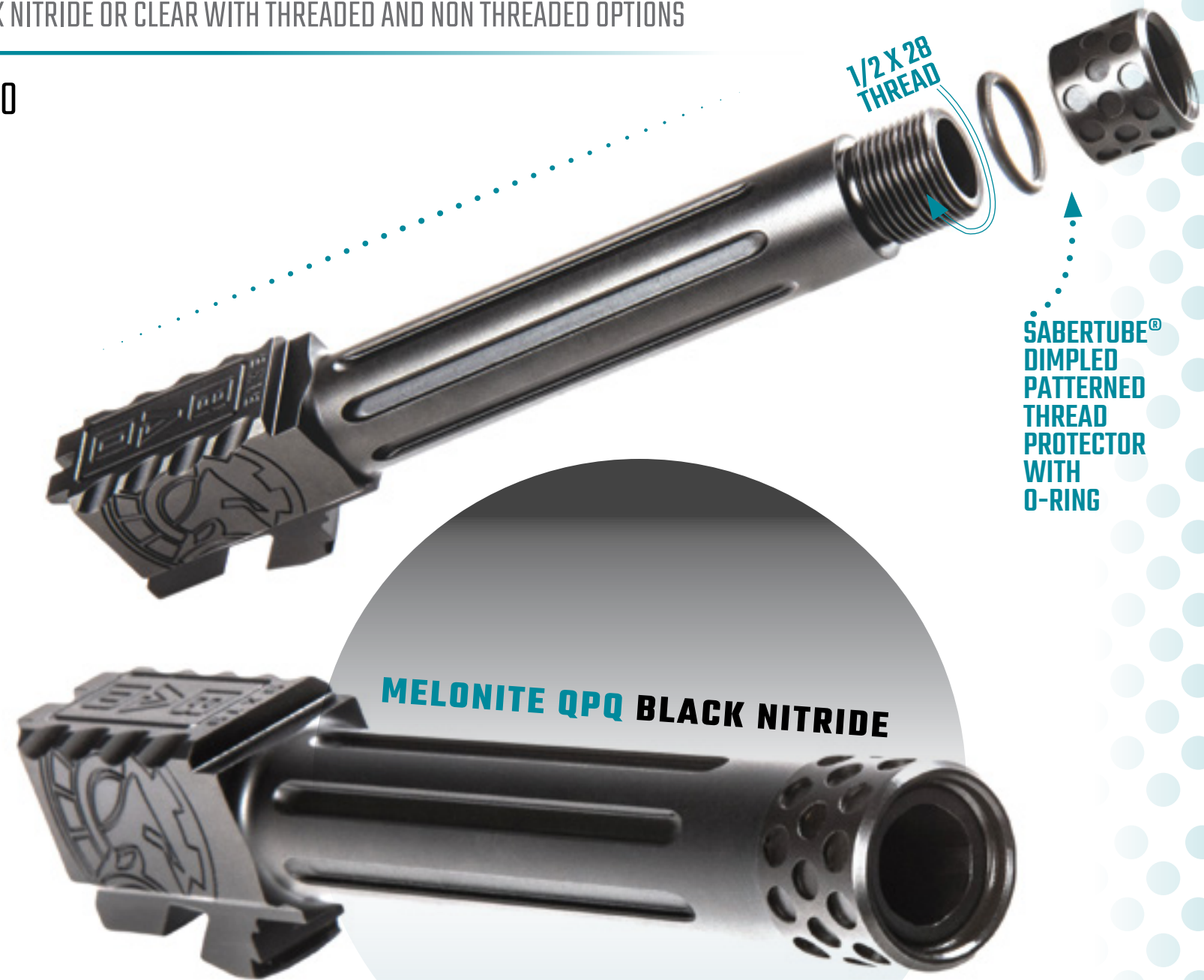

**ONE:1** UTILIZES REVOLUTIONARY MACHINING PROCESS WHERE ONE MACHINE COMPREHENSIVELY MACHINES EVERY PART OF THE BARREL FROM THE BEGINNING TO THE END. THE PROCESS INCLUDES THE ULTRA-PRECISE SINGLE POINT CUT RIFLING WHERE THE RIFLING IS DONE WITH ALMOST A HUNDRED MINUSCULE CUTS.

THIS METHOD DOES NOT INTRODUCE STRESS TO THE BARREL AND NO STRESS RELIEVING IS NECESSARY AFTER RIFLING. PERFECT CONCENTRICITY BETWEEN CHAMBER, BORE AND RIFLING. THIS PROCESS ALSO YIELDS UNIFORM TWIST RATE AND ULTRA-ACCURATE RIFLING GROOVES WITH DEVIATION OF LESS THAN .0001" FROM GROOVE DEPTH TO GROOVE DEPTH.

MATERIAL:	HEAT TREATED 4140 CM STEEL
THREAD:	1/2 X 28 THREAD
FLUTING:	STRAIGHT
FINISH:	MELONITE QPQ BLACK NITRIDE
TWIST RATE:	1:10
THREAD PROTECTOR:	SABERTUBE® DIMPLED PATTERNED THREAD PROTECTOR WITH O-RING
CROWN:	11° TARGET CROWN
ENGRAVING:	BATTLEARMS LOGO
MADE IN USA	
GLOCK 19 GEN 1-5 (INCLUDING 19X)	



CLEAR

# BATTLEARMS™ 9MM 4150CM 5R NITRIDE 10.5" & 16"

\$200.00 AND UP

- MATERIAL: 4150 CHROME MOLLY STEEL
- INSPECTION: MAGNETIC PARTICLE INSPECTED
- RIFLING: 6 GROOVE BUTTON RIFLING
- FINISH: SALT BATH QPQ NITRIDE (INSIDE & OUTSIDE)
- CALIBER: 9MM
- CHAMBER: 9MM NATO CHAMBER
- CROWN: 11 DEG TARGET CROWN
- TWIST RATE: 1:10 RH TWIST
- LENGTH: 16IN OR 10.5IN
- PROFILE: PROPRIETARY TAPERED PROFILE
- GAS SYSTEM: BLOWBACK
- MUZZLE THREAD: 1/2IN-36 (SEE NOTE)
- BARREL EXTENSION: 9MM
- WEIGHT: 16IN 1 LB 12.7 OZ, 10.5IN 15.6OZ
- HEAT TREAT: DOUBLE HEAT TREAT STRESS RELIEVED
- MULTI-POINT QUALITY CONTROL INSPECTION
- NOTE: 1/2IN-36 MUZZLE THREAD USED TO PREVENT ACCIDENTAL INSTALLATION OF .22 CALIBER (1/2IN-28 THREADED) MUZZLE DEVICES ON THE 9MM BARREL.



10.5"

16"

# BATTLEARMS™ 308WIN 4150CM 5R NITRIDE 16" & 18"

\$300.00 AND UP

- MATERIAL: 4150 CHROME MOLLY STEEL
- INSPECTION: MAGNETIC PARTICLE INSPECTED
- RIFLING: 5R RIFLING
- FINISH: SALT BATH QPQ NITRIDE (INSIDE & OUTSIDE)
- CALIBER: 308 WIN
- CROWN: 11 DEG TARGET CROWN
- TWIST RATE: 1:10 RH TWIST
- LENGTHS: 18IN OR 16IN
- GAS SYSTEM: 16IN MID LENGTH, 18IN RIFLE LENGTH
- MUZZLE THREAD: 5/8INX24
- GAS BLOCK DIAMETER: .750IN
- GAS BLOCK JOURNAL LENGTH: 1.1IN
- GAS PORT DIAMETER: 0.091
- BARREL EXTENSION: M4
- HEAT TREAT: DOUBLE HEAT TREAT STRESS RELIEVED
- MULTI-POINT QUALITY CONTROL INSPECTION
- NOTES: (1.) GAS BLOCK AND GAS TUBE NOT INCLUDED.



16"

18"

# BATTLEARMS™ 300BLK 4150CM 5R NITRIDE BARREL 7.5", 10.5", 16"

\$230.00 AND UP

- BATTLEARMS™ 300BLK BARREL, 5R RIFLING, 4150CM, QPQ NITRIDE, CARBINE GAS
- MATERIAL: 4150 CHROME MOLLY STEEL
- INSPECTION: MAGNETIC PARTICLE INSPECTED
- RIFLING: 5R RIFLING
- FINISH: SALT BATH QPQ NITRIDE (INSIDE & OUTSIDE)
- CALIBER: 300BLK AAC
- CROWN: 11 DEG TARGET CROWN
- TWIST RATE: 1:8 RH TWIST
- LENGTHS: 16IN, 10.5IN, 7.5IN
- GAS SYSTEM: 16IN CARBINE LENGTH, 10.5 AND 7.5 PISTOL LENGTH
- MUZZLE THREAD: 5/8-24;
- GAS BLOCK DIAMETER: .750IN
- GAS BLOCK JOURNAL LENGTH: 1.1IN
- GAS PORT DIAMETER: 16IN .119IN, 10.5IN .080, 7.5IN .080
- BARREL EXTENSION: M4
- WEIGHT: 16IN 1 LB 12.7OZ, 10.5IN 1 LB 3.6OZ, 7.5IN 15.3OZ
- HEAT TREAT: DOUBLE HEAT TREAT STRESS RELIEVED
- MULTI-POINT QUALITY CONTROL INSPECTION
- ALL NFA RULES APPLY
- NOTES: (1.) GAS BLOCK AND GAS TUBE NOT INCLUDED. (2.) GAS PORT DIAMETER MAY NEED TO BE OPENED UP PENDING ON FINAL WEAPON CONFIGURATION IN SUPER/SUB SONIC, SUPPRESSED/UNSUPPRESSED, MIL-SPEC CARBINE BUFFER/VERT BUFFER SYSTEM, AMMUNITION TYPE, ETC.



7.5"

10.5"

16"



# BATTLEARMS RACK™

- BATTLEARMS™ RACK AMBIDEXTROUS CHARGING HANDLE
- U.S. UTILITY PATENT NO. 9964371, 9810494, 9587896.
- NO WEAK ROLL PINS
- DESIGNED WITH NO ROLL PINS.
- SMOOTH SLIDING LATCH
- PATENTED LATCH SYSTEM SLIDES PARALLEL WITH THE RECEIVER NOTCH FOR SLICK AND QUICK RELEASE AND SIMULTANEOUSLY MINIMIZES WEAR.
- ASYMMETRIC CHARGING
- PURPOSE BUILT WITH ASYMMETRIC USE IN MIND, THE RACK™
- MONOLITHIC MODULAR HANDLE
- MACHINED FROM SINGLE PIECE OF ALUMINUM,
- COATED IN A HARD ANODIZED BLACK FINISH.

\$125.00



# BATTLEARMS™ THUMPER™ MUZZLE BRAKE

\$70.00 AND UP

- 17-4 STAINLESS STEEL
- THREADED 1/2 X 28
- 5/8 X 24
- 1/2 X 36
- 22CAL (2.23/5.56)





# GAS BLOCKS



**BAD-LGB-TI-625** | \$85.00  
LIGHTWEIGHT LOW PROFILE TITANIUM GAS BLOCK .625" DIA - RAW TITANIUM FINISH



**BAD-LGB-TI-625-B** | \$95.00  
LIGHTWEIGHT LOW PROFILE TITANIUM GAS BLOCK .625" - DIA BLACK IONBOND PVD



**BAD-LGB-TI-750** | \$95.00  
LIGHTWEIGHT LOW PROFILE TITANIUM GAS BLOCK .750" DIA - RAW TITANIUM FINISH



**BAD-LGB-TI-750-B** | \$105.00  
LIGHTWEIGHT LOW PROFILE TITANIUM GAS BLOCK .750" - DIA BLACK IONBOND PVD



**BAD-LGB-FE-750** | \$39.95  
LIGHTWEIGHT LOW PROFILE STEEL GAS BLOCK .750"

# BAD BOLT CARRIER GROUPS

## BAD-BCG-M16

M16 COMPLETE BOLT CARRIER GROUP  
9310 BOLT, BLACK NITRIDE FINISH

\$145



- 9310 BOLT
- SHOT PEENED
- STAKED GAS KEY
- MAGNETIC PARTICLE INSPECTED
- HIGH PRESSURE TESTED
- GRADE 8 FASTENERS
- MADE IN USA

## BAD-EBCG-M16

FULL AUTO M16 COMPLETE BOLT CARRIER GROUP  
9310 BOLT, BLACK NITRIDE FINISH

\$199<sup>.95</sup>



## BATTLEARMS ENHANCED 9MM BLOWBACK AR-15 BOLT

BOLT CARRIER GROUP  
BLACK NITRIDE FINISH

\$169<sup>.95</sup>

ENHANCED 9MM BLOWBACK AR-15 BOLT CARRIER GROUP IS COMPATIBLE WITH BOTH COLT AND GLOCK MAGAZINE CONFIGURATIONS. FEATURES RELIABLE AR-15 STYLE EXTRACTOR CLAW WITH O-RING AND SPRING AND BROAD TRIGGER COMPATIBILITY WITH RAMPED BOTTOM GEOMETRY. CHARGING HANDLE INTERFACES DIRECTLY ON BOLT CARRIER SURFACE THAT CAN WITHSTAND VIGOROUS PULLING FORCE WITHOUT THE WORRY OF SHEARING OFF THE CARRIER KEY. REINFORCED FIRING PIN IS HELD IN PLACE WITH STANDARD FIRING PIN COTTER PIN.

### SPECS:

- 9MM BLOWBACK AR-15 BOLT CARRIER GROUP
- GLOCK AND COLT MAGAZINE COMPATIBLE
- MILSPEC 8620 HEAT TREATED STEEL CARRIER
- RELIABLE EXTERNAL AR-15 STYLE EXTRACTOR
- FULL-AUTO COMPATIBLE
- COMPATIBLE WITH MOST AR-15 TRIGGERS
- DURABLE HARD NITRIDE BLACK FINISH
- REMOVABLE CARRIER WEIGHT
- COMPATIBLE WITH DUST COVER
- TOTAL MASS: 14.9 OUNCES
- COMPATIBLE WITH BAD-CSS 9MM BUFFER



## BOLT CARRIER GROUP AR-308 DPMS PATTERN BLACK NITRIDE

BOLT CARRIER GROUP  
BLACK NITRIDE FINISH

\$250<sup>.00</sup>



- MPI TESTED AND MARKED
- NITRIDE FINISH INSIDE AND OUTSIDE
- WITH FORWARD ASSIST CUTS
- CORRECT AUTO SEAR TRIP LOCATION
- 9310 HEAD
- 8620 CARRIER
- FOR 7.62 NATO, .308 WINCHESTER OR SIMILAR
- INCLUDES O-RING EXTRACTOR HELPER TO RUN UNDER ALL CONDITIONS
- WILL WORK WITH DPMS FORWARD ASSIST OR REAR AERO STYLE FORWARD ASSIST

# RIGIDRAIL™



- PROPRIETARY RIGIDRAIL™ RAIL DESIGN TO BALANCE BETWEEN LIGHT WEIGHT AND STRENGTH/RIGIDITY
- PARTIAL PICATINNY TOP RAIL (MATCHING BAD556-LW LIGHT-WEIGHT UPPER RECEIVER)
- MATERIAL: AIRCRAFT GRADE 6061-T6 ALUMINUM
- INNER DIAMETER: 1.315"
- M-LOK SLOTS AT 3, 6, 9, AND PARTIAL 12 O'CLOCK POSITIONS
- ADDITIONAL SINGLE M-LOK SLOTS AT (4) 45° POSITIONS FOR FORWARD MOUNTING LIGHT, LASER, ETC.
- BARREL NUT DIAMETER: 1.378"
- BARREL NUT: 7075 ALUMINUM TYPE 3 CLASS 2 HARD ANODIZED CLEAR (BRONZE FINISH)
- BARREL NUT WRENCH INCLUDED
- NO BARREL NUT SHIMS REQUIRED FOR INSTALLATION
- 17-4PH CORED STAINLESS STEEL RAIL MOUNTING ATTACHMENT - PATENT PENDING BY CMT
- (4) ANTI ROTATION QD SLING SOCKETS: (2) AT FRONT AND (2) AT REAR. 3 O'CLOCK & 9 O'CLOCK POSITIONS
- NO CONTACT WITH GAS TUBE
- COMPATIBLE WITH MOST LOW PROFILE GAS BLOCKS
- WEIGHT: 5.9 OZ WITH BARREL NUT AND MOUNTING HARDWARE
- INTERNAL DIAMETER: 1.34"
- ROTATION LIMITED QD SOCKETS
- FINISH: MIL-SPEC TYPE 3 CLASS 2 HARD-COAT ANODIZED
- MADE IN THE USA!

## BATTLEARMS RIGIDRAIL™ 6.7" M-LOK

\$219.<sup>00</sup>

## BATTLEARMS RIGIDRAIL™ 9.5" M-LOK

\$229.<sup>95</sup>

## BATTLEARMS RIGIDRAIL™ 13.7" M-LOK

\$249.<sup>95</sup>

## BATTLEARMS RIGIDRAIL™ 15" M-LOK

\$279.<sup>95</sup>

## BATTLEARMS RIGIDRAIL™ 17" M-LOK

\$295.<sup>95</sup>

6.7"



9.5"



13.7"



15"



17"



# RIGIDRAIL™

## M-LOK DPMS/AR/LR-308



- PROPRIETARY RIGIDRAIL™ RAIL DESIGN TO BALANCE BETWEEN LIGHT WEIGHT AND STRENGTH/RIGIDITY
- PARTIAL PICATINNY TOP RAIL (MATCHING BAD762 LIGHTWEIGHT UPPER RECEIVER)
- MATERIAL: AIRCRAFT GRADE 6061-T6 ALUMINUM
- OVERALL LENGTH: 15IN
- INNER DIAMETER: 1.43IN
- MAXIMUM SUPPRESSOR INTERNAL: 1.1875IN
- M-LOK SLOTS AT 3, 6, 9, AND PARTIAL 12 O'CLOCK POSITIONS
- ADDITIONAL SINGLE M-LOK SLOTS AT (4) 45° POSITIONS FOR FORWARD MOUNTING LIGHT, LASER, ETC.
- BARREL NUT: 7075 ALUMINUM TYPE 3 CLASS 2 HARD ANODIZED CLEAR (BRONZE FINISH)

- BARREL NUT WRENCH INCLUDED
- NO BARREL NUT SHIMS REQUIRED FOR INSTALLATION
- 17-4PH CORED STAINLESS STEEL RAIL MOUNTING ATTACHMENT - PATENT PENDING BY CMT
- (4) ANTI ROTATION QD SLING SOCKETS: (2) AT THE FRONT AND (2) AT THE REAR. 3 & 9 O'CLOCK POSITIONS
- NO CONTACT WITH GAS TUBE
- COMPATIBLE WITH MOST LOW PROFILE GAS BLOCKS
- WEIGHT: 13.7OZ WITH HARDWARE
- ROTATION LIMITED QD SOCKETS
- FINISH: MIL-SPEC TYPE 3 CLASS 2 HARD-COAT ANODIZED
- COMPATIBLE WITH DPMS AR-10 UPPER RECEIVERS
- MADE IN THE USA!



# BATTLEARMST™ CARBON FIBER HAND GUARD 10IN MLOK

BROWNELLS EXCLUSIVE PRODUCT \$ 289



- BATTLEARMST™ CARBON FIBER HAND GUARD 10IN MLOK
- THE PROPERTIES OF THE CARBON FIBER, SPECIFICALLY ITS LOW THERMAL MASS COMBINED WITH ITS HIGH THERMAL CONDUCTIVITY, AND THE PATTERN IN WHICH THE MATERIAL ORIENTATION IS LAID OUT, CREATES THE MOST EFFICIENT HANDGUARD IN TERMS OF HEAT DISSIPATION.
- THIS TRANSLATES INTO THE SHOOTER BEING ABLE TO COMFORTABLY HANDLE THE GUN AFTER HUNDREDS OF ROUNDS HAVE BEEN SENT DOWNRANGE.
- SPECIFICATIONS
- LENGTH: 10IN
- INSIDE DIAMETER: 1.786IN
- OUTSIDE DIAMETER: 1.932IN
- MATERIAL: 35-50 CARBON FIBER WITH 7075 ALUMINUM BARREL NUT
- ATTACHMENT: MLOK ACCESSORY COMPATIBLE
- WEIGHT: 5.2OZ WITH BARREL NUT

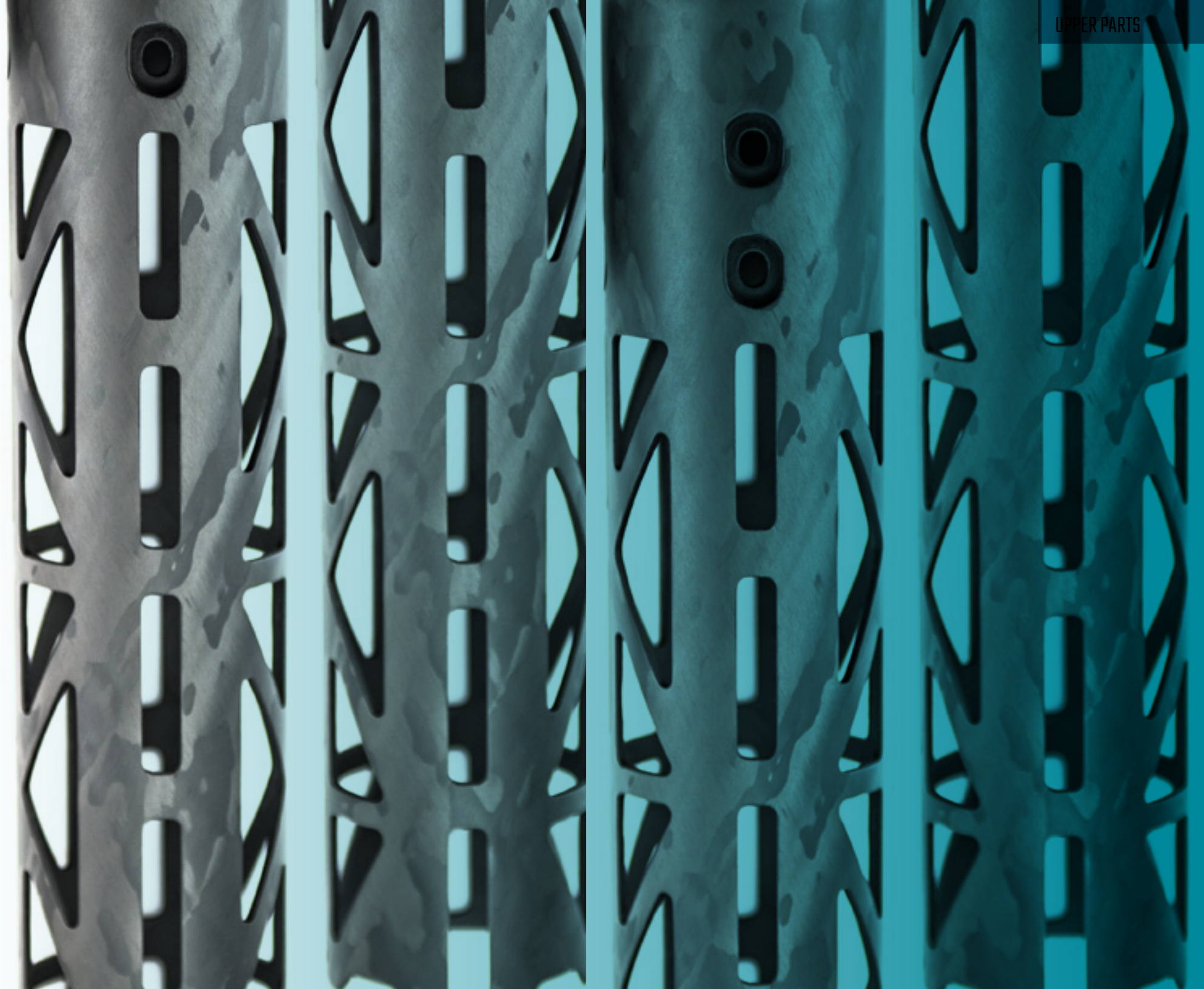



ABSOLUTE CO-WITNESS

LOWER 1/3

- PRECISION CNC MACHINED FROM BILLET 7075T6 ALUMINUM
- LIGHTWEIGHT DESIGN
- AVAILABLE IN EITHER LOWER 1/3 OR ABSOLUTE CO-WITNESS
- SINGLE PIECE DESIGN
- SIMPLE ROCK-ON & TIGHTEN MOUNT TO MIL-SPEC PICATINNY RAIL
- HARD COAT ANODIZED BLACK
- WEIGHT: ABSOLUTE CO-WITNESS : 0.60 OZ (MOUNT ONLY) / 0.78 OZ (WITH TWO CROSS BOLTS)
- WEIGHT: LOWER 1/3 : 0.71 OZ (MOUNT ONLY) / 0.88 OZ (WITH TWO CROSS BOLTS)

# BAD-LOM™ LIGHTWEIGHT OPTIC MOUNT

ABSOLUTE CO-WITNESS AND LOWER 1/3 | FOR THE TRIJICON MRO (MINIATURE RIFLE OPTIC)

\$75.00



# BAD-LOM™



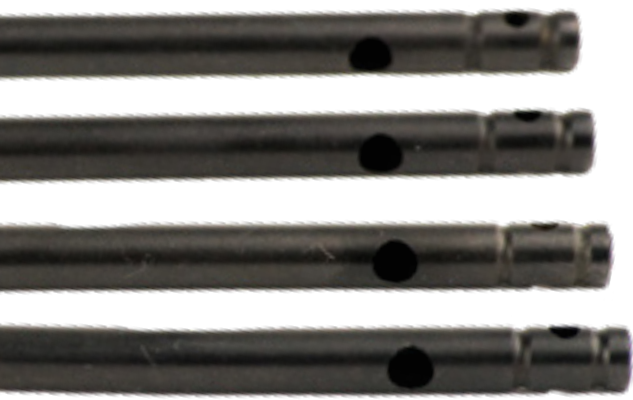

SPRINGS / PINS / GAS TUBES



**EJECTION PORT COVER DOOR**  
(NO PIN, C-CLIP, SPRING)  
\$6.00



8448532  
**EJECTION PORT COVER SPRING**  
\$1.00



8448533  
**EJECTION PORT COVER PIN**  
\$2.00



00000000  
**C-CLIP**  
\$2.00



**AR-15 PISTOL LENGTH GAS TUBE**  
- STAINLESS STEEL  
\$16.50



**AR-15 CARBINE LENGTH GAS TUBE**  
- STAINLESS STEEL  
\$15.00



**AR-15 MID LENGTH GAS TUBE**  
- STAINLESS STEEL  
\$15.00



**AR-15 RIFLE LENGTH GAS TUBE**  
- STAINLESS STEEL  
\$15.00



**AR-15/M16 PISTOL LENGTH GAS TUBE**  
- BLACK MELONITE  
\$18.50



**AR-15/M16 CARBINE LENGTH GAS TUBE**  
- BLACK MELONITE  
\$17.00



**AR-15 MID LENGTH GAS TUBE**  
- BLACK MELONITE  
\$17.00



**AR-15 RIFLE LENGTH GAS TUBE**  
- BLACK MELONITE  
\$17.00



**AR15/M16/M4 EJECTION PORT COVER ASSEMBLY - COMPLETE**  
INCLUDES: EJECTION PORT COVER, HINGE PIN, COVER SPRING AND HINGE PIN C-CLIP  
\$7.99



**AR15 / M16 EJECTOR / SAFETY SELECTOR DETENT SPRING**  
\$.50

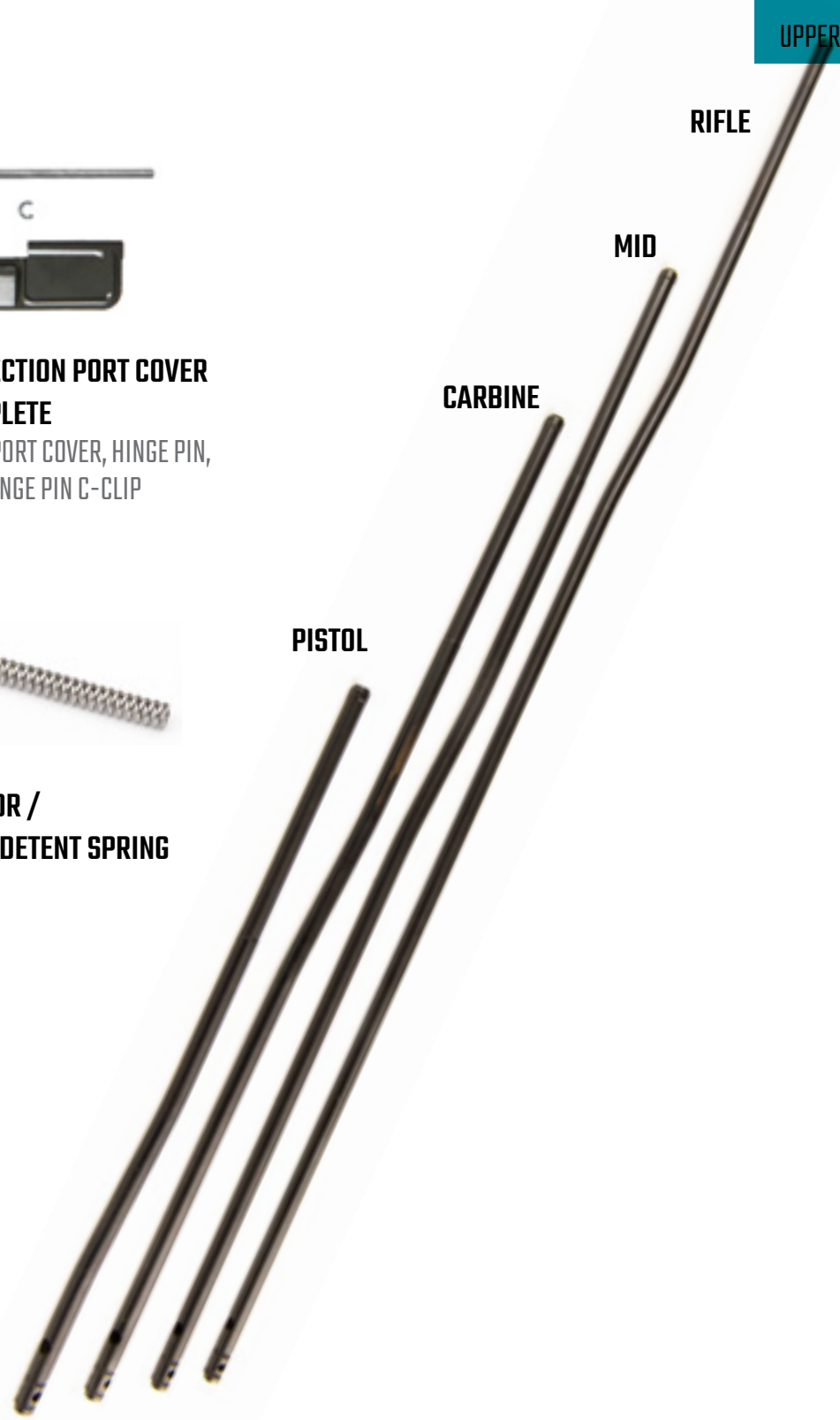



# LOWER PARTS

MAG RELEASES / BOLT CATCH / GRIPS / KITS

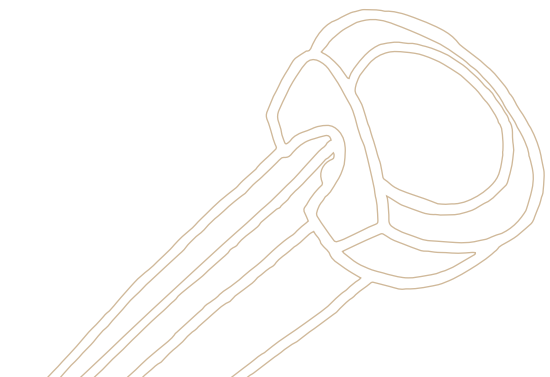



EXCELLENT **ERGONOMIC FEEL.**

# BAD ENHANCED MAGAZINE RELEASE

THE CONCAVE V-GROOVE BUTTON FACE OFFERS EXCELLENT ERGONOMIC FEEL AND SELF-CENTERS THE INDEX FINGER AS PRESSURE IS APPLIED. THE HORIZONTAL, PARALLEL SERRATIONS HELPS SLIPPAGE IN THE VERTICAL ORIENTATION WHILE MINIMIZING DRAG IN THE HORIZONTAL DIRECTION FOR FINGER RETRACTION.

THE BAD-EMR ALSO FEATURES A LIGHTWEIGHT SKELETONIZE BACK TO OFFSET THE WEIGHT GAINED FROM THE FULLY SOLID BUTTON FACE AND SLIGHTLY INCREASED HEIGHT TO EQUAL THE WEIGHT OF THE STANDARD MIL-SPEC MAGAZINE RELEASE (APPROXIMATELY 0.002 LBS). BAD-EMR IS COMPATIBLE WITH ALL LOWER RECEIVERS THAT ACCEPTS MIL-SPEC MAGAZINE RELEASE BUTTONS.



**BAD-EMR** | \$7.00

ENHANCED MAGAZINE RELEASE  
ANODIZED BLACK



**BAD-EMR** | \$11.00

ENHANCED MAGAZINE RELEASE  
CERAKOTE FDE



**BAD-EMR** | \$7.00

ENHANCED MAGAZINE RELEASE  
ANODIZED SILVER



**BAD-EMR** | \$11.00

ENHANCED MAGAZINE RELEASE  
CERAKOTE SMITH & WESSON RED



**BAD-EMR** | \$7.00

ENHANCED MAGAZINE RELEASE  
ANODIZED RED



**BAD-EMR** | \$11.00

ENHANCED MAGAZINE RELEASE  
CERAKOTE OD GREEN



SKELETONIZED  
BACK MAKES HER  
LIGHTWEIGHT

CNC MACHINED FROM A SOLID  
PIECE OF 7075-T6 ALUMINUM

# BAD ENHANCED MODULAR MAGAZINE RELEASE

THE BAD-EMMR FEATURES AN UNIQUE, PATENT PENDING THREE SIDED DOVETAIL FINGER PAD ATTACHMENT MECHANISM THAT ALLOWS FOR MAXIMUM STRENGTH, AN ALMOST UNINTERRUPTED FINGER PAD FACE FOR MAXIMUM DESIGN AESTHETICS, LIGHT WEIGHT AND LOW PROFILE DESIGN. THE INTERCHANGEABLE FINGER PADS OFFERS EXCELLENT ERGONOMIC FEEL AND EASE OF OPERATION WITHOUT SHIFTING GRIP POSITION. IF YOU ARE LOOKING FOR MAXIMUM FLEXIBILITY, ROBUST DESIGN AND UNPARALLELED DESIGN AESTHETICS, THE BAD-EMMR IS THE ULTIMATE EXTENDED MAGAZINE RELEASE FOR YOU.

AVAILABLE IN 5 COLORS: ANODIZED SILVER • ANODIZED BLACK • ANODIZED RED • FDE CERAKOTE • CERAKOTE OD GREEN

**BAD-EMMR MEDIUM** | \$21.95 AND UP  
ENHANCED MODULAR MAGAZINE RELEASE



**BAD-EMMR LARGE** | \$23.95 AND UP  
ENHANCED MODULAR MAGAZINE RELEASE



# BATTLEARMS MAGAZINE RELEASE KIT

CONSISTING OF:  
QTY 1 BAD-EMC-IC  
QTY 1 MAGAZINE CATCH SPRING  
QTY 1 BAD-EMR-B OR BAD-EMMR-L-B  
BATTLEARMS ENHANCED MAGAZINE CATCH - BAD-EMC-IC

- PROCESS: INVESTMENT CAST (SAME PROCESS AS MIL-SPEC)
- MATERIAL: 8620 HEAT TREATED STEEL FINISH: BLACK PHOSPHATE FINISH
- CONSTRUCTION: ONE PIECE ENGINEERING (NOT TWO-PIECE)
- DESIGN: LIGHTWEIGHT FLUTED DESIGN
- COMPATIBILITY: COMPATIBLE WITH MIL-SPEC MAGAZINE RELEASE BUTTON, BAD-EMR, BAD-EMMR, ETC.
- LENGTH: SHORTER THREADED PIN TO REDUCE INSTALLED MAGAZINE BUTTON PROFILE OF SOLID FACE MAGAZINE RELEASE BUTTONS
- WEIGHT: 0.25 OZ (V.S. 0.32 OZ MIL-SPEC)
- BAD-EMR (ENHANCED MAGAZINE RELEASE) FOR THE AR15/AR10.
- BAD-EMMR-L-B (ENHANCED MODULAR MAGAZINE RELEASE - LARGE FINGER PAD - BLACK) FOR THE AR15/AR10.



# BAD ENHANCED PIN SET





- AR15 / M16 / M4 COMPATIBLE - FITS ALL AR15/M16/M4 LOWER RECEIVERS WITH MIL-SPEC .250" DIAMETER FRONT PIVOT AND REAR TAKE-DOWN PIN HOLES.
- PATENT PENDING PIVOT PIN & TAKE-DOWN PIN HEAD DESIGNS - GREATLY IMPROVED GRIPPING SURFACE AND PULL STRENGTH WITHOUT THE USE OF OVERSIZE HEADS.
- LOW PROFILE PIN HEADS - LOW DRAG AND NEVER IN THE WAY. LOWER PROFILE THAN MIL-SPEC PIN HEADS.
- AMBIDEXTROUS SAFETY COMPATIBLE - THE ENHANCED TAKE-DOWN PIN - TITANIUM (BAD-ETP-TI) HEAD DESIGN DOES NOT OBSTRUCT THE USE OF THE RIGHT SIDE AMBI SAFETY SELECTOR LEVER.
- EXTENDED PIN TIPS (+0.030" OVER MILSPEC) - ADDED TIP LENGTH NOTICEABLY AIDS IN STARTING/PUSHING THE PINS OUT FROM THE LEFT SIDE OF THE RECEIVER, WITHOUT UNDUE PROTRUSION.
- BULLET TIP GUIDE - CONE SHAPED RECESS AT BOTH PIN TIPS PREVENT ACCIDENTAL BULLET OR TOOL SLIP AND REDUCES THE CHANCE OF SCRATCHING/DAMAGING OF THE RECEIVER.
- PATENT PENDING EZ GUIDE CHANNEL - THE ADDITIONAL EZ GUIDE CHANNEL PROVIDES ASSISTED INSTALLATION OF THE BAD-EPP-TI (ENHANCED PIVOT PIN - TITANIUM).
- WEIGHT - 0.256 OZ (0.128 OZ FOR TAKE-DOWN PIN AND 0.160 OZ FOR PIVOT PIN)

**BAD-EPS** | \$29.95 AND UP  
**ENHANCED PIN SET**  
 CNC MACHINED FROM ROUND STOCK STEEL BARS  
 CASE HARDENED AND FINISHED IN MILSPEC BLACK  
 MANGANESE PHOSPHATE

**BAD-EPS-308** | \$34.95  
**LR-308/SR-25/AR308**  
 CNC MACHINED FROM ROUND STOCK STEEL BARS  
 CASE HARDENED AND FINISHED IN MILSPEC BLACK  
 MANGANESE PHOSPHATE



 **BAD-EPS-TI** | \$38.95 AND UP  
**TITANIUM ENHANCED PIN SET**  
 CNC MACHINED FROM GRADE 5 TITANIUM BARS  
 THESE BEAUTIES ARE IN ITS NATURAL MACHINED TITANIUM  
 FINISH AND ARE 50% LIGHTER THAN THE MIL-SPEC PIN SET

 **BAD-EPS-TI-B** | \$43.95 AND UP  
**TITANIUM ENHANCED PIN SET**  
 CNC MACHINED FROM GRADE 5 TITANIUM BARS  
 FINISHED IN BLACK IONBOND DLC (DIAMOND-LIKE COATING).  
 50% LIGHTER THAN MIL-SPEC PIN SET.

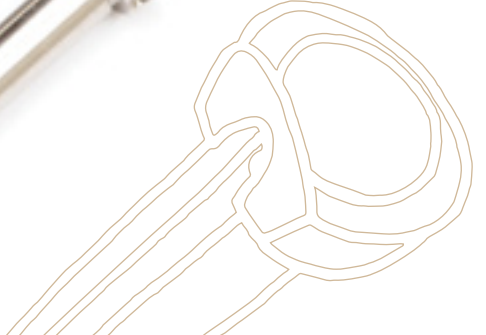

SET ALSO INCLUDES:  
 2 - KNS HARDENED STAINLESS STEEL DETENTS  
 2 - 17-7 NICKEL PLATED STAINLESS STEEL PIN SPRINGS  
 1 - MAGNET







PATENT PENDING  
R10556-LV CAL: MULT. SN: 1003000

Trijicon MRO  
1 CLICK = 1/2 MOA  
Patent Pending



# BAD ENHANCED BOLT CATCH

**BAD-EBC** | \$42.00

**ENHANCED BOLT CATCH - BLACK**

ENHANCED CONTROL SURFACES, BETTER ERGONOMICS, LIGHTWEIGHT ENGINEERING, STRONG BILLET 8620 HEAT TREATED STEEL, PRECISION CNC MACHINED, AND VERSATILE MODULAR DESIGN FOR FUTURE ADD-ON PRODUCT(S).



400% MORE SURFACE AREA

- PRECISION CNC BILLET 8620 HEAT TREATED STEEL (NOT CAST OR MIM)
- OVERSIZE CONTROL SURFACES FOR EASY ENGAGEMENT
- LIGHTWEIGHT BUT ROBUST DESIGN (0.42OZ - SAME AS MILSPEC BOLT CATCH WITH SMALLER CONTROL SURFACES)
- RAISED "T-SHAPED" HEEL PROVIDES POSITIVE AND DISTINCTIVE CONTROL SURFACE FOR BOLT LOCK BACK
- COMPATIBLE WITH NORGON AMBI-CATCH WITHOUT INTERFERENCE
- ELEGANT TAPERED CONTROL SURFACE AND SKELETONIZED DESIGN
- BOLD HORIZONTAL AND DIAGONAL SERRATIONS PROVIDES POSITIVE PURCHASE
- VERSATILE, MODULAR DESIGN FOR FUTURE ADD-ON PRODUCT(S)
- BLACK OXIDE FINISH

### BAD-EBC-TI | \$99.95

**BILLET ENHANCED BOLT CATCH - TITANIUM**  
ENHANCED CONTROL SURFACES, BETTER ERGONOMICS, LIGHTWEIGHT ENGINEERING, STRONG BILLET TITANIUM PRECISION CNC MACHINED, AND VERSATILE MODULAR DESIGN FOR FUTURE ADD-ON PRODUCT/S.



OR



### BAD-EBC-IC | \$15.00

**AR15/M16 ENHANCED BOLT CATCH - INVESTMENT CAST**

- WEIGHT 0.39OZ
- COMPATIBLE WITH NORGON AMBI-CATCH WITHOUT INTERFERENCE
- RAISED "T-SHAPED" HEEL PROVIDES POSITIVE AND DISTINCTIVE CONTROL SURFACE FOR BOLT LOCK BACK
- BOLD HORIZONTAL AND DIAGONAL SERRATIONS PROVIDES POSITIVE PURCHASE
- 8620 HEAT TREATED CAST STEEL
- BLACK PHOSPHATE FINISH
- WITH THIS UPGRADE YOU HAVE A VERSATILE MODULAR DESIGN, ENHANCED CONTROL SURFACES, LIGHTWEIGHT ENGINEERING, AND BETTER ERGONOMICS.

### BAD-EBC-9MM | \$42.00

**BATTLEARMS™ 9MM ENHANCED BOLT CATCH**  
BILLET CNC NON-SKELETONIZED



### BATTLEARMS™ 3 PIECE ENHANCED LOWER PARTS KIT | \$35.00

INCLUDES THE FOLLOWING:

#### ENHANCED BOLT CATCH (BAD-EBC-IC),

THE AR-15 CAST ENHANCED BOLT CATCH IS 8620 HEAT TREATED CAST STEEL WITH A MANGANESE PHOSPHATE BLACK FINISH.

LIGHTWEIGHT AND ROBUST DESIGN 0.39OZ

COMPATIBLE WITH NORGON AMBI-CATCH WITHOUT INTERFERENCE

RAISED "T-SHAPED" HEEL PROVIDES POSITIVE AND DISTINCTIVE CONTROL SURFACE FOR BOLT LOCK BACK

BOLD HORIZONTAL AND DIAGONAL SERRATIONS PROVIDES POSITIVE PURCHASE

ENHANCED SINGLE SIDED SAFETY SELECTOR (BAD-E4S-IC) FOR THE AR15 STYLE RIFLES.

#### SINGLE SIDE SAFETY SELECTOR (0°-90° SEMI AUTO)

FIT ALL MIL-SPEC DIMENSIONED AR-15 LOWER RECEIVER

INVESTMENT CAST 8620 HEAT TREATED STEEL

ENHANCED MAGAZINE CATCH - BAD-EMC-IC

PROCESS: INVESTMENT CAST (SAME PROCESS AS MIL-SPEC)

MATERIAL: 8620 HEAT TREATED STEEL

FINISH: BLACK PHOSPHATE FINISH

CONSTRUCTION: ONE PIECE ENGINEERING (NOT TWO-PIECE)

DESIGN: LIGHTWEIGHT FLUTED DESIGN

COMPATIBILITY: COMPATIBLE WITH MIL-SPEC MAGAZINE RELEASE BUTTON, BAD-EMR, BAD-EMMR, ETC.

LENGTH: SHORTER THREADED PIN TO REDUCE INSTALLED MAGAZINE BUTTON PROFILE OF SOLID FACE MAGAZINE RELEASE BUTTONS

WEIGHT: 0.25 OZ (V.S. 0.32 OZ MIL-SPEC)

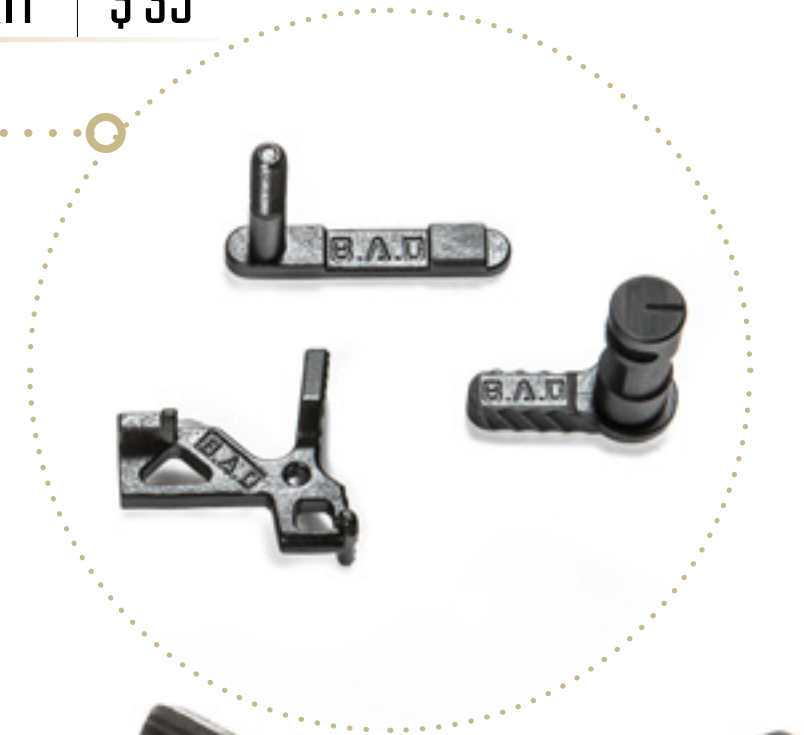

# BAD-LPK-PKX ENHANCED COMPLETE LOWER PARTS KIT | \$ 135.00



**CONSISTING OF:**

**BAD-EBC-IC ENHANCED BOLT CATCH**

- LIGHTWEIGHT BUT ROBUST DESIGN 0.39OZ
- COMPATIBLE WITH NORCON AMBI-CATCH WITHOUT INTERFERENCE
- RAISED "T-SHAPED" HEEL PROVIDES POSITIVE AND DISTINCTIVE CONTROL SURFACE FOR BOLT LOCK BACK
- BOLD HORIZONTAL AND DIAGONAL SERRATIONS PROVIDES POSITIVE PURCHASE
- 8620 HEAT TREATED CAST STEEL
- BLACK PHOSPHATE FINISH

**BAD-E4S-IC ENHANCED SINGLE SIDED SAFETY SELECTOR**

- BASED ON OUR FAMOUS BAD-ASS AMBIDEXTROUS SAFETY SELECTOR WITH DISTINCTIVE AND DIAGONAL SERRATIONS.
- SINGLE SIDE SAFETY SELECTOR (0°-90° SEMI AUTO)
- FIT ALL MIL-SPEC DIMENSIONED AR-15 LOWER RECEIVER
- BLACK PHOSPHATE FINISH
- INVESTMENT CAST 8620 HEAT TREATED STEEL

**BAD-EMC-IC ENHANCED MAGAZINE CATCH**

- PROCESS: INVESTMENT CAST (SAME PROCESS AS MIL-SPEC)
- MATERIAL: 8620 HEAT TREATED STEEL FINISH: BLACK PHOSPHATE FINISH
- CONSTRUCTION: ONE PIECE ENGINEERING (NOT TWO-PIECE)
- DESIGN: LIGHTWEIGHT FLUTED DESIGN
- COMPATIBILITY: COMPATIBLE WITH MIL-SPEC MAGAZINE RELEASE BUTTON, BAD-EMR, BAD-EMMR, ETC.
- LENGTH: SHORTER THREADED PIN TO REDUCE INSTALLED MAGAZINE BUTTON PROFILE OF SOLID FACE MAGAZINE RELEASE BUTTONS
- WEIGHT: 0.25 OZ (V.S. 0.32 OZ MIL-SPEC)

**BAD-EMR ENHANCED MAGAZINE RELEASE**

- PRECISION CNC MACHINED FOR BILLET 7075-T6 ALUMINUM (NOT 6061) IN AN ANODIZED BLACK FINISH, THE BAD-EMR FEATURES A UNIQUE, FULLY SOLID "V" SHAPED BUTTON FACE WITH HORIZONTAL SERRATIONS (NO THROUGH HOLE).
- THE CONCAVE V-GROOVE BUTTON FACE OFFERS AN EXCELLENT ERGONOMIC FEEL AND SELF-CENTERS THE INDEX FINGER AS PRESSURE IS APPLIED. THE HORIZONTAL, PARALLEL SERRATIONS HELP SLIPPAGE IN THE VERTICAL ORIENTATION WHILE MINIMIZING DRAG IN THE HORIZONTAL DIRECTION FOR FINGER RETRACTION.
- THE BAD-EMR ALSO FEATURES A LIGHTWEIGHT SKELETONIZED BACK TO OFFSET THE WEIGHT GAINED FROM THE FULLY SOLID BUTTON FACE AND SLIGHTLY INCREASED HEIGHT TO EQUAL THE WEIGHT OF THE STANDARD MIL-SPEC MAGAZINE RELEASE (APPROXIMATELY 0.002 LBS).
- BAD-EMR IS COMPATIBLE WITH ALL LOWER RECEIVERS THAT ACCEPT MIL-SPEC MAGAZINE RELEASE BUTTONS.

**BAD-ATG™ ADJUSTABLE TACTICAL GRIP**

- ADJUSTABLE TACTICAL GRIP EASILY ADJUSTS, WITH THE INCLUDED HEX KEY, TO EACH OF THE THREE MOST POPULAR INDUSTRY PROVEN ANGLES (17, 25, & 33 DEGREES) USING THE PATENT PENDING ADJUSTABLE ANGLE MECHANISM.
- THE TEXTURED FINGER GROOVES AND RIBBED BACK-STRAP OPTIMIZE COMFORT AND PROVIDE POSITIVE CONTROL.
- DIMPLED AIR GAPS HELP KEEP HAND DRY WHILE OFFERING FIRM GRIP TEXTURE.
- ONLY 3.0OZ COMPLETE WITH SCREW AND WASHER!

**BAD-EPS TAKEDOWN AND PIVOT PINS:**

- AR15 / M16 / M4 COMPATIBLE - FITS ALL AR15/M16/M4 LOWER RECEIVERS WITH MIL-SPEC .250IN DIAMETER FRONT PIVOT AND REAR TAKEDOWN PIN HOLES.
- PATENT PENDING PIVOT PIN & TAKEDOWN PIN HEAD DESIGNS - GREATLY IMPROVED GRIPPING SURFACE AND PULL STRENGTH WITHOUT THE USE OF OVERSIZED HEADS.
- LOW PROFILE PIN HEADS - LOW DRAG AND NEVER IN THE WAY. LOWER PROFILE THAN MIL-SPEC PINHEADS.
- AMBIDEXTROUS SAFETY COMPATIBLE - THE ENHANCED TAKEDOWN PIN (BAD-ETP) HEAD DESIGN DOES NOT OBSTRUCT THE USE OF THE RIGHT SIDE AMBIDEXTROUS SAFETY SELECTOR LEVER.
- EXTENDED PIN TIPS (+0.030" OVER MIL-SPEC) - ADDED TIP LENGTH NOTICEABLY AIDS IN STARTING/PUSHING THE PINS OUT FROM THE LEFT SIDE OF THE RECEIVER, WITHOUT UNDUCE PROTRUSION.
- BULLET TIP GUIDE - CONE SHAPED RECESS AT BOTH PIN TIPS PREVENT ACCIDENTAL BULLET OR TOOL SLIP AND REDUCED THE CHANCE OF SCRATCHING/DAMAGING OF THE RECEIVER.
- PATENT PENDING EZ GUIDE CHANNEL & MAGNETIC ASSIST INSTALL - EASY, HAS-SLE-FREE MAGNET ASSISTED INSTALLATION OF THE EPP (ENHANCED PIVOT PIN). NO MORE LOST DETENTS AND SPRINGS.
- EACH BAD-EPS COMES WITH (1) BAD-ETP, (1) BAD-EPP, (2) KNS HARDENED STAINLESS STEEL DETENTS, (2) 17-7 NICKEL PLATED STAINLESS STEEL PIN SPRINGS, AND (1) HIGH-STRENGTH NEODYMIUM MAGNET FOR HASSLE-FREE MAGNET ASSISTED INSTALLATION OF THE ENHANCED PIVOT PIN (BAD-EPP).

QTY 1 MIL-SPEC TRIGGER	QTY 1 BOLT CATCH SPRING
QTY 1 MIL-SPEC HAMMER	QTY 1 TRIGGER GUARD
QTY 1 DISCONNECTOR	QTY 1 TRIGGER GUARD ROLL PIN
QTY 1 DISCONNECTOR SPRING	QTY 2 HAMMER / TRIGGER PINS MIL-SPEC
QTY 1 HAMMER SPRING	QTY 1 SAFETY SELECTOR DETENT
QTY 1 TRIGGER SPRING	QTY 1 SAFETY SELECTOR DETENT SPRING
QTY 2 TAKEDOWN / PIVOT PIN SPRINGS	QTY 1 MAGAZINE CATCH SPRING
QTY 2 TAKEDOWN / PIVOT PIN DETENTS	QTY 1 BUFFER RETAINER DETENT
QTY 1 BOLT CATCH DETENT	QTY 1 BUFFER RETAINER DETENT SPRING



# BAD-QRRTP

\$30.00

## THE NEW BATTLEARMS QUICK RELEASE REAR TAKE DOWN PIN™

This pin was designed as a retention device only and to streamline the reloading process by working in-conjunction with devices designed and intended to require the upper be lifted upwards and away from the lower receiver using the front pivot pin as the fulcrum, before the magazine may be removed. This product is not designed and intended as a legal compliance device or product. Battle Arms Development makes no claims or guarantees that this particular product will alone, or in-conjunction with any other device, render any firearm lawful under any State, Federal, or Local laws. If you are purchasing this device to maintain or alter the legal status of your firearm, please consult with an attorney familiar with your local, state, and federal laws. By purchasing this product, you acknowledge that you understand the above and will hold Battle Arms Development, Inc. and any of its employees, agents, dealers, distributors and affiliates free and harmless from and against any and all losses, penalties, damages, settlements, costs, legal expenses or liabilities of every kind.

### FEATURES

- DUAL FUNCTION
- EASY PULL HEAD
- CNC MACHINED
- MADE IN THE USA!
- PATENT PENDING

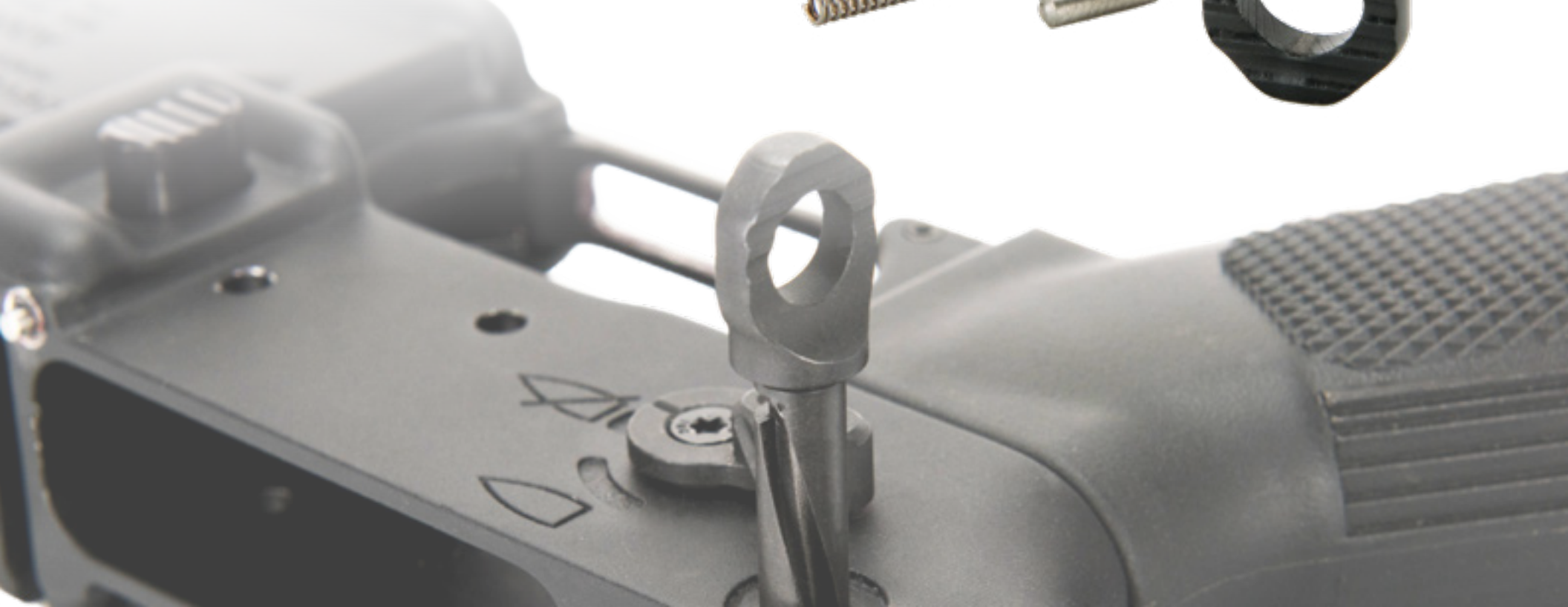



# BAD ADJUSTABLE TACTICAL GRIP

THE BATTLE ARMS DEVELOPMENT BAD-ATG™ (ADJUSTABLE TACTICAL GRIP) EASILY ADJUSTS, WITH THE INCLUDED HEX KEY, TO EACH OF THE THREE MOST POPULAR INDUSTRY PROVEN ANGLES (17, 25, & 33 DEGREES) USING THE PATENT PENDING ADJUSTABLE ANGLE MECHANISM. THE TEXTURED FINGER GROOVES AND RIBBED BACK-STRAP OPTIMIZE COMFORT AND PROVIDES POSITIVE CONTROL. DIMPLED AIR GAPS HELP KEEP HAND DRY WHILE OFFERING FIRM GRIP TEXTURE. ONLY 3.00Z COMPLETE WITH SCREW AND WASHER!

THREE MOST POPULAR INDUSTRY-PROVEN ANGLES: 17°, 25°, & 33° • ONLY 30Z - INCLUDING SCREW AND WASHER

17°  
25°  
33°

DIMPLED AIR GAPS KEEPS HANDS DRY AND OFFERS FIRM GRIP TEXTURE

TEXTURED FINGER GROOVES AND RIBBED BACK-STRAP OPTIMIZE COMFORT AND PROVIDES POSITIVE CONTROL

**BAD-ATG** | \$25.00

**ADJUSTABLE TACTICAL GRIP**  
PATENT PENDING ADJUSTABLE ANGLE MECHANISM



**TITANIUM PISTOL GRIP SCREWS**

GRADE 5 TITANIUM GRIP SCREW FOR THE AR15 / M4 / M16. STRONGER THAN STEEL AT ABOUT HALF THE WEIGHT. PERFECT FOR THAT LIGHTWEIGHT RIFLE BUILD. ONLY 0.140Z! NOT COMPATIBLE WITH BAD-ATG GRIPS

\$6.95

AVAILABLE IN: **BLACK, FDE, OD GREEN, AND GREY**

# B.A.D TT-15 ADJUSTABLE TRIGGER

By **T** TRIGGERTECH



## BAD-TT-15-S & BAD-TT-15-C | \$245.00 EA.

ADJUSTABLE TACTICAL GRIP | SEMI AUTO STRAIGHT TRIGGER

THIS PRODUCT IS A COLLABORATION WITH TRIGGERTECH, A CANADIAN COMPANY KNOWN FOR THEIR PATENTED FRICTIONLESS RELEASE TECHNOLOGY THAT LEADS TO A TRUE ZERO-CREEP RELEASE DUE TO THEIR DI-PIN BEARING SYSTEM. THIS DROP-IN TRIGGER MODULAR DESIGN IS ADJUSTABLE FROM 2.5 TO 5 POUNDS IN 2 OUNCE INCREMENTS WITH EACH CLICK.

STRAIGHT FLAT FACE TRIGGER LEVER

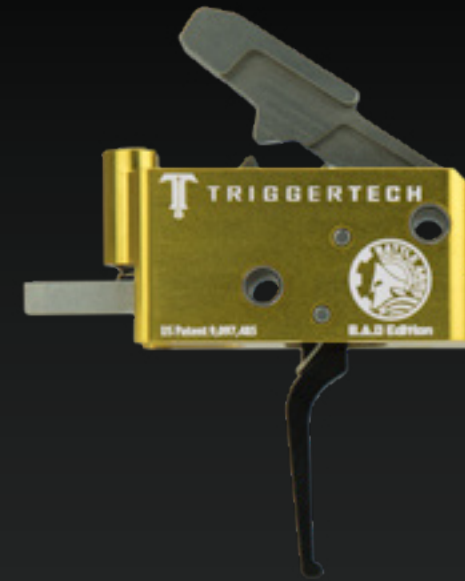

CURVED FACE TRIGGER LEVER



- Short Two Stage Action, designed to feel like a 1911 trigger
- Enhanced Reset Control™ leading to sub .030" reset
- Optimal hammer spring and geometry for the highest possible performance

- All Stainless Steel 440C internal components with 6061 aluminum anodized housing
- Straight drop-in to .154" pin (not applicable for .169" Colt)
- NOTE: Pins not included

- Repeatable User Adjustable Trigger Pull from 2.5 to 5 lbs with click feedback indications



- Patented Frictionless Release Technology (FRT)™ Zero Creep; US Patent 9,097,485



LOWER PARTS

MIL SPEC BUFFER TUBE

-?

\$?



8448730B

M4 CARBINE BUFFER ASSEMBLY

- STANDARD WEIGHT

\$12.00



8441122

M4 CARBINE ACTION SPRING

\$4.00



AR15 BOLT CATCH

\$8.00



AR15 BOLT CATCH DETENT

\$1.25



8448433

AR15 BOLT CATCH SPRING

\$1.50



AR15 - BUFFER RETAINER (DETENT)

\$2.50



8448583

AR15 - BUFFER RETAINER (DETENT) SPRING

IN 17-7 NICKEL COATED STAINLESS STEEL

\$1.00



TITANIUM PISTOL GRIP SCREWS

GRADE 5 TITANIUM GRIP SCREW FOR THE AR15 / M4 / M16. STRONGER THAN STEEL AT ABOUT HALF THE WEIGHT. PERFECT FOR THAT LIGHTWEIGHT RIFLE BUILD. ONLY 0.14OZ! NOT COMPATIBLE WITH BAD-ATG GRIPS

\$6.95



AR15 RECEIVER EXTENSION NUT (CASTLE NUT)

\$7.00



9390021

M4 STYLE RECEIVER END PLATE FOR AR15/M4

- BLACK - FOR CARBINE BUFFER TUBES

\$5.99



BAD-EMC-IC - AR15 CAST ENHANCED MAGAZINE CATCH

- BLACK PHOSPHATE FINISH

\$9.00



8448637

AR15 MAGAZINE CATCH SPRING

\$3.00



AR15/M16 TAKEDOWN & PIVOT PIN SS DETENT

\$0.85



AR15/M16 TAKEDOWN & PIVOT PIN DETENT SPRING

IN 17-7 NICKEL COATED STAINLESS STEEL

\$0.75



BATTLE ARMS DEVELOPMENT ENHANCED TAKEDOWN PIN (BAD-ETP)

FOR THE AR15 / M16 / M4 STYLE RIFLES. PRECISION SWISS CNC MACHINED FROM ROUND STOCK STEEL BARS, THE BAD-ETP IS CASE HARDENED AND FINISHED IN MIL-SPEC BLACK MAGANESE PHOSPHATE.

\$14.95



BAD ENHANCED TAKEDOWN PIN - TITANIUM (BAD-ETP-TI)

FOR THE AR15 / M16 / M4 STYLE RIFLES. PRECISION MACHINED FROM GRADE 5 TITANIUM, THE BAD-ETP-TI IS IN NATURAL MACHINED FINISH. 50% LIGHTER THAN MIL-SPEC STEEL PINS!

\$19.95



BAD ENHANCED PIVOT PIN (BAD-EPP)

FOR THE AR15 / M16 / M4 STYLE RIFLES. PRECISION SWISS CNC MACHINED FROM ROUND STOCK STEEL BARS, THE BAD-EPP IS CASE HARDENED AND FINISHED IN MIL-SPEC BLACK MAGANESE PHOSPHATE.

\$17.95

BAD ENHANCED PIVOT PIN - TITANIUM (BAD-EPP-TI)

FOR THE AR15 / M16 / M4 STYLE RIFLES. PRECISION MACHINED FROM GRADE 5 TITANIUM, THE BAD-EPP-TI IS IN NATURAL MACHINED FINISH. 50% LIGHTER THAN MIL-SPEC STEEL PINS!

\$22.95



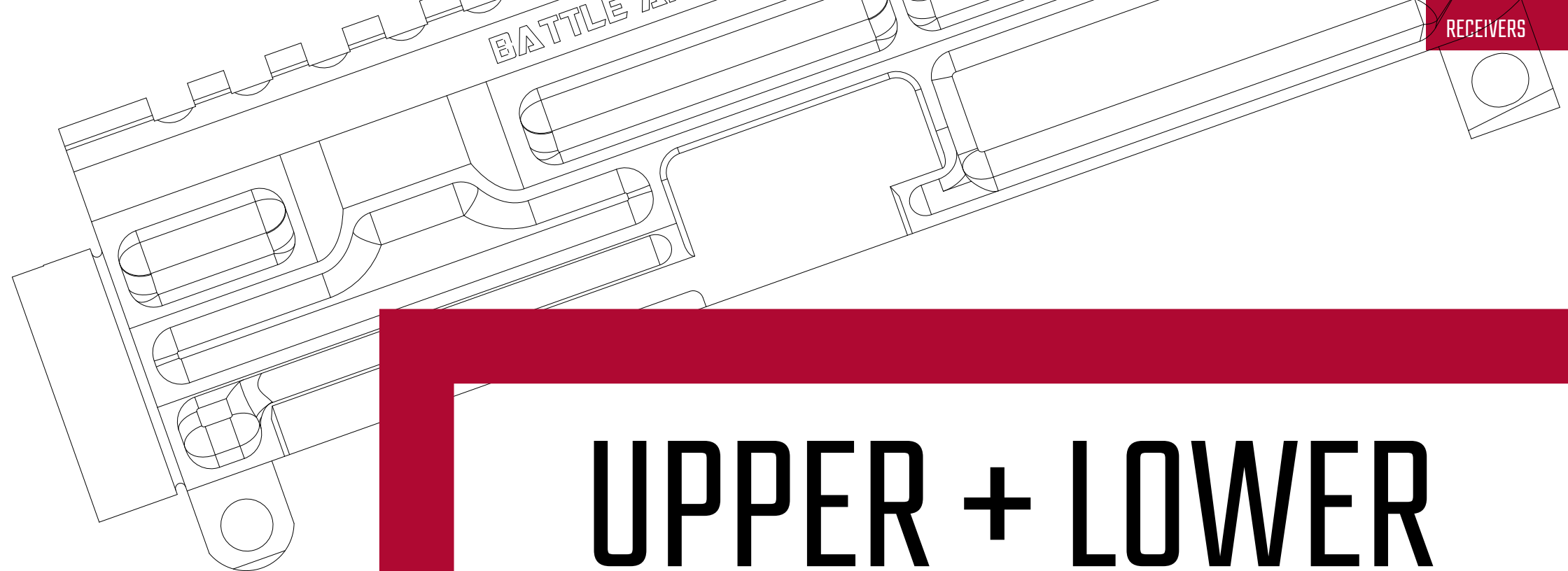

# UPPER + LOWER RECEIVERS

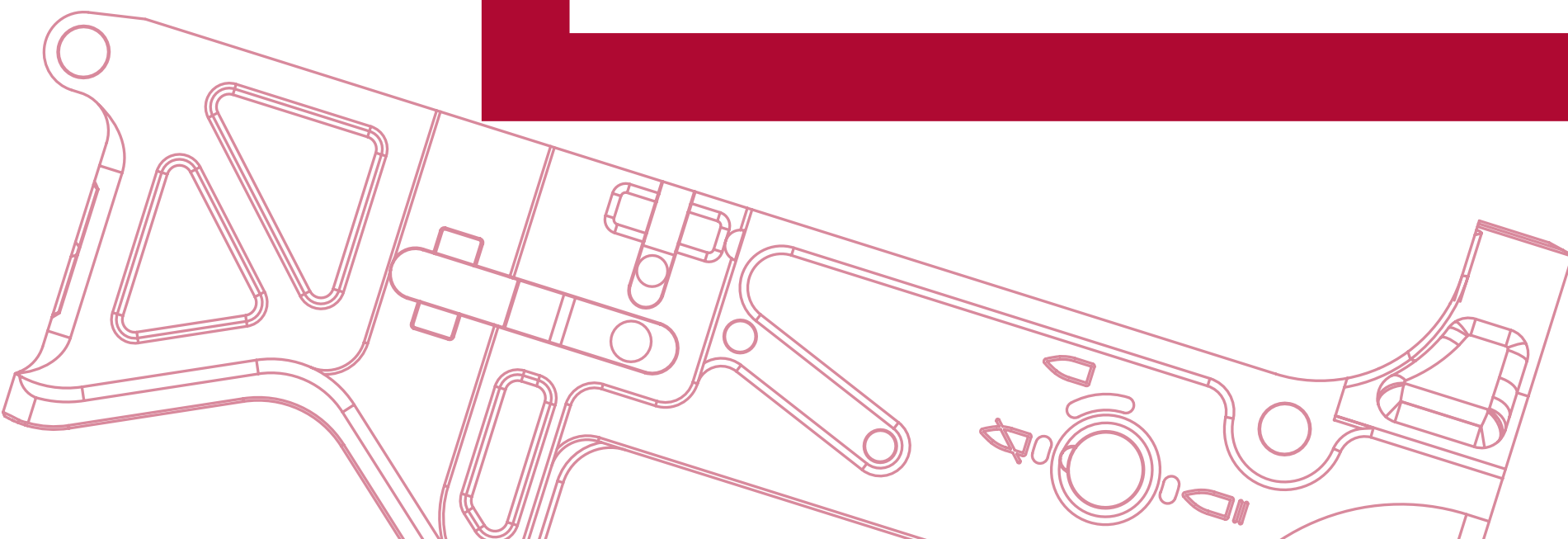
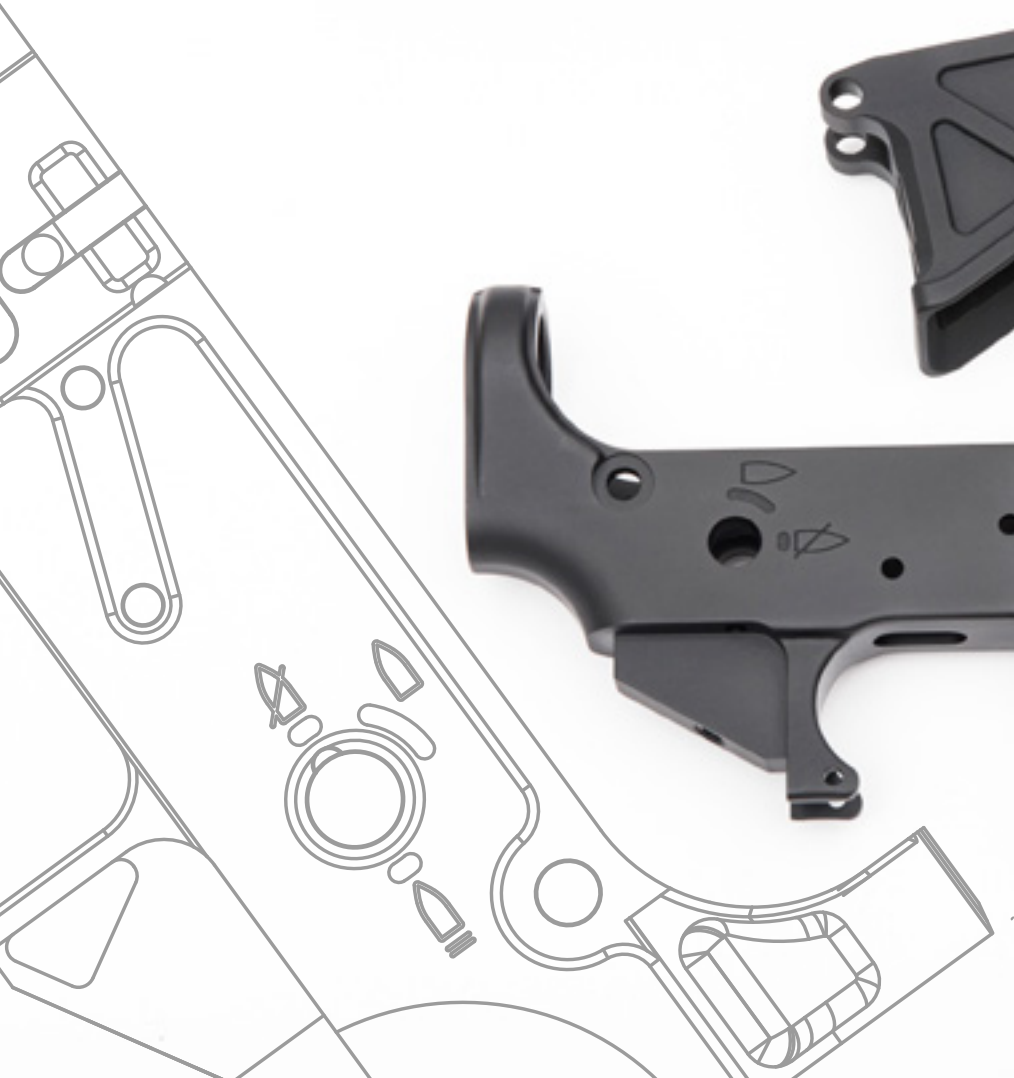



# BAD762 AR308 BILLET RECEIVER SET

BAD762 AMBIDEXTROUS BILLET RECEIVER SET IN 7075-T6 AIRCRAFT GRADE ALUMINUM, WIRE EDM MAG WELL BLACK ANODIZED FINISH

**\$660.00**

### LOWER RECEIVER SPECIFICATIONS:

- PRECISION CNC FROM BILLET 7075-T6 AEROSPACE ALUMINUM
- PATENTED LIGHTWEIGHT DESIGN
- HIGH PRECISION WIRE EDM CNC MAG WELL
- MIL-A-8825F, TYPE III, CLASS 2, HARD ANODIZED BLACK FINISH
- COMPATIBLE WITH DPMS 308 LOWER PART KITS
- PROPRIETARY AMBIDEXTROUS MAGAZINE AND BOLT RELEASE (INCLUDED)
- DIMENSIONAL ACCURACY INSPECTION
- ALL SHARP EDGES DE-BURRED SHARP BY HAND
- PICTOGRAPH SELECTOR MARKINGS PROPERLY MARKED FOR 90° SAFETY OR BAD-ASS-ST / BAD-CASS-ST SHORT THROW AMBIDEXTROUS SAFETY SELECTORS
- RECEIVER SAFETY SELECTOR HOLE & INTERNAL WALL MACHINED WITH RELIEF CUT FOR BATTLE ARMS DEVELOPMENT SHORT-THROW / REVERSIBLE AMBIDEXTROUS SAFETY SELECTORS (BAD-ASS-ST AND BAD-CASS-SA-ST)
- MULTI CALIBER MARKING FOR BUILD VERSATILITY
- FLARED, DEEP BEVELED MAGWELL
- EASY IN INSTALL SET SCREW BOLT CATCH PIN (PIN INCLUDED)
- CAPTURED TAKEDOWN PIN DETENT SPRING (SET SCREW INCLUDED)
- UPPER/LOWER RECEIVER TENSION SCREW (SCREW INCLUDED)
- INTEGRATED TRIGGER GUARD

### UPPER RECEIVER SPECIFICATIONS:

- PRECISION CNC FROM BILLET 7075-T6 AEROSPACE ALUMINUM
- PATENTED LIGHTWEIGHT DESIGN
- MACHINED T-MARKS
- MIL-A-8825F, TYPE III, CLASS 2, HARD ANODIZED BLACK FINISH
- COMPATIBLE WITH DPMS PATTERN LOWER RECEIVERS
- ALL COMPONENTS, MATERIAL, AND PACKAGING MADE IN THE USA
- UPPER LOWER COMBINED WEIGHT 200Z

### \*RIGIDRAIL™ SPECIFICATIONS

- PROPRIETARY RIGIDRAIL™ RAIL DESIGN TO BALANCE BETWEEN LIGHT WEIGHT AND STRENGTH/RIGIDITY
- PARTIAL PICATINNY TOP RAIL (MATCHING BAD762 UPPER RECEIVER)
- MATERIAL: AIRCRAFT GRADE 6061-T6 ALUMINUM
- M-LOK SLOTS AT 3, 6, 9, AND PARTIAL 12 O'CLOCK POSITIONS
- ADDITIONAL SINGLE M-LOK SLOTS AT (4) 45° POSITIONS FOR FORWARD MOUNTING LIGHT, LASER, ETC.
- BARREL NUT: 7075 ALUMINUM TYPE 3 CLASS 2 HARD ANODIZED CLEAR (BRONZE FINISH)
- BARREL NUT WRENCH INCLUDED
- NO BARREL NUT SHIMS REQUIRED FOR INSTALLATION
- 17-4PH CORED STAINLESS STEEL RAIL MOUNTING ATTACHMENT - PATENT PENDING BY CMT
- (4) ANTI ROTATION QD SLING SOCKETS: (2) AT FRONT AND (2) AT REAR. 3 O'CLOCK & 9 O'CLOCK POSITIONS
- TAPPED HOLE AT FRONT END FOR OPTIONAL BIPOD/SLING ATTACH POINT AT 6 O'CLOCK POSITION
- NO CONTACT WITH GAS TUBE
- COMPATIBLE WITH MOST LOW PROFILE GAS BLOCKS
- ROTATION LIMITED QD SOCKETS
- FINISH: MIL-SPEC TYPE 3 CLASS 2 HARD-COAT ANODIZED BLACK
- WEIGHT: 13.70Z



**\* RAIL OPTIONAL**

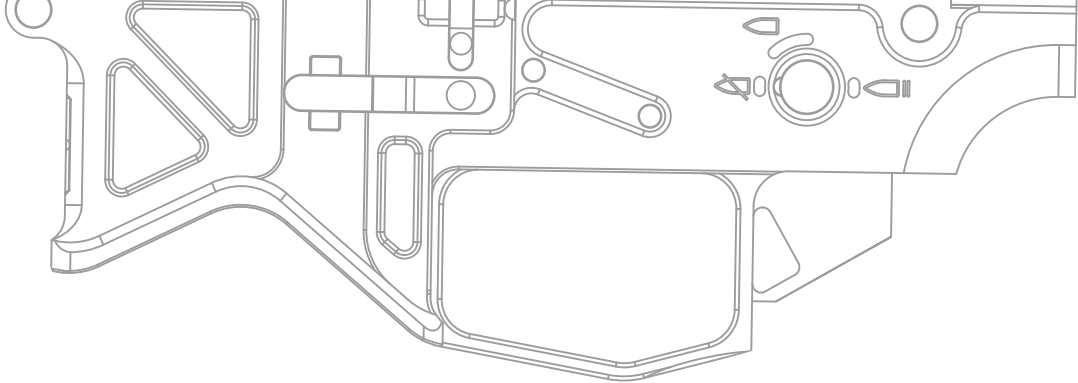

# 5 WAYS TO LOSE WEIGHT FAST

WITH OUR LIGHTWEIGHT UPPER + LOWER RECEIVERS



**BAD-15** PREMIUM FORGED LOWER RECEIVER - GEN 2  
7075-T6 WITH WIRE EDM MAGWELL

 **BAD556-LW-UR** LIGHTWEIGHT BILLET UPPER RECEIVER  
7075-T6 BILLET UPPER RECEIVER

 **BAD556-LW-LR** LIGHTWEIGHT BILLET LOWER RECEIVER  
7075-T6 BILLET LOWER RECEIVER

 **BAD556-LW-SET** LIGHTWEIGHT BILLET LOWER RECEIVER SET  
7075-T6 BILLET LOWER RECEIVER SET

**BAD-PDW** MONOLITHIC PDW LOWER RECEIVER & STOCK SYSTEM  
COMPLETE LOWER RECEIVER SET

## THE BAD-15 PREMIUM FORGED LOWER RECEIVER | \$209.00 AND UP

7075-T6 WITH WIRE EDM MAGWELL - GEN 1 + GEN 2

SPECIFICATIONS:

- QUALITY AEROSPACE 7075-T6 ALUMINUM ALLOY RAW FORGING (NO SECONDS OR IMPROPERLY HEAT TREATED FORGINGS)
- ULTRA PRECISE WIRE EDM CUT MAGWELL FOR DIMENSIONAL CONSISTENCY AND RELIABILITY (NOT CNC OR BROACHED)
- 3D HIGH POWER, DEEP LASER ENGRAVED LOGO, TEXT AND FIRE MARKINGS PRIOR TO ANODIZATION. RAZOR SHARP IMAGE QUALITY (NO LOGO BLURR OR INCONSISTENT ENGRAVING DEPTHS)
- PRECISION REAMED TO SIZE HOLES FOR THE PIVOT PIN, TAKEDOWN PIN, HAMMER PIN, TRIGGER PIN, AND SAFETY SELECTOR (NOT SIMPLY DRILLED TO SIZE)
- RECEIVER EXTENSION THREAD MACHINED WITH HIGH PRECISION AND LOW STRESS HELICAL THREADING (NOT DRILLED AND TAPPED)
- BEAD BLAST & ACID ETCH IMMEDIATELY PRIOR TO ANODIZING FOR UNIFORM FINISH AND TO AVOID OXIDATION AND CONTAMINATION
- MIL-A-8625F, TYPE III, CLASS 2, HARD ANODIZED FLAT BLACK FINISH
- COMPATIBLE WITH TOP/MIL STANDARD AR LOWER RECEIVER PARTS
- DIMENSIONAL ACCURACY INSPECTION
- ALL SHARP EDGES DE-BURRED BY HAND
- LEGACY M16/M4 SELECTOR STOPS REMOVED AND BLENDED SMOOTH TO RECEIVER (NO TRACE OF SELECTOR STOPS REMAIN)
- PICTOGRAPH SELECTOR MARKINGS PROPERLY MARKED FOR 90° SAFETY OR BAD-ASS-ST / BAD-CASS-ST SHORT THROW AMBIDEXTROUS SAFETY SELECTORS
- RECEIVER SAFETY SELECTOR HOLE MACHINED WITH RELIEF CUT FOR BATTLE ARMS DEVELOPMENT "SHORT THROW" AMBIDEXTROUS SAFETY SELECTORS
- MULTI CALIBER MARKING FOR BUILD VERSATILITY
- DEEP MAGWELL BEVEL CUT



**GEN 2 FEATURES-**  
EASY IN INSTALL SET SCREW BOLT CATCH PIN (PIN INCLUDED)  
CAPTURED TAKEDOWN PIN DETENT SPRING (SET SCREW INCLUDED)  
UPPER/LOWER RECEIVER TENSION SCREW (SCREW INCLUDED)



AVAILABLE IN 4 COLORS-  
MAGPUL FDE CERAKOTE - GEN 1  
BLACK CERAKOTE - GEN 2  
MAGPUL OD GREEN CERAKOTE - GEN 2

# BAD556-LW

LIGHTWEIGHT BILLET UPPER RECEIVER - GEN 2

\$259.<sup>95</sup> AND UP



- PRECISION CNC FROM BILLET 7075-T6
- AEROSPACE ALUMINUM
- PATENT PENDING LIGHTWEIGHT DESIGN
- M4 FEED RAMP
- MACHINED T-MARKS
- LASER ENGRAVED LOGO
- MIL-A-8625F, TYPE III, CLASS 2, HARD
- ANODIZED FLAT BLACK FINISH
- COMPATIBLE WITH TDP/MIL STANDARD AR
- UPPER RECEIVER PARTS
- ALL COMPONENTS, MATERIAL, AND
- PACKAGING MADE IN THE USA

+ ALSO AVAILABLE IN FDE CERAKOTE FINISH

**GEN 2 FEATURES:**  
LIGHTER WEIGHT (6.32 OZ TO 6.28 OZ)  
COMPATIBLE WITH FORTIS REV II RAIL (WITH INDEXING TABS)

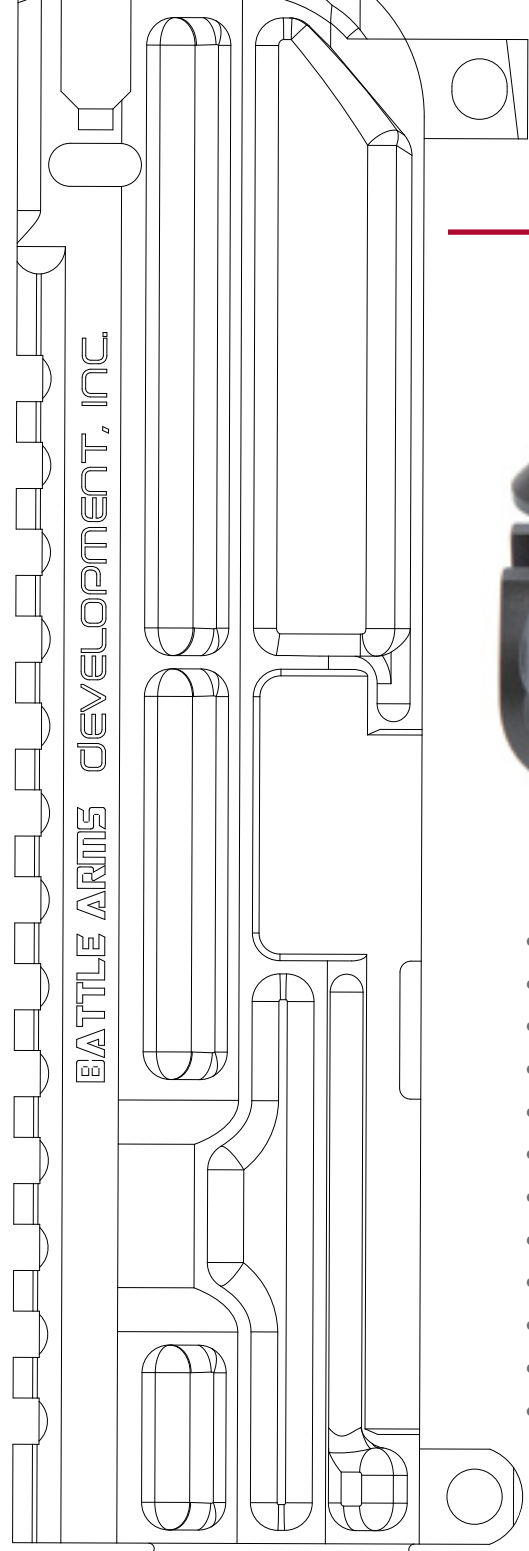



AEROSPACE 7075-T6 ALUMINUM



PRECISION WIRE EDM CUT MAGAZINE WELL



ANODIZED FLAT BLACK FINISH



# BAD556-LW

LIGHTWEIGHT BILLET LOWER RECEIVER

\$289.<sup>95</sup> AND UP

- PATENT PENDING LIGHTWEIGHT DESIGN
- MIL-A-8625F, TYPE III, CLASS 2, HARD
- COMPATIBLE WITH TDP/MIL STANDARD AR LOWER RECEIVER PARTS
- DIMENSIONAL ACCURACY INSPECTION
- ALL SHARP EDGES DE-BURRED SHARP BY HAND
- PICTOGRAPH SELECTOR MARKINGS PROPERLY
- MARKED FOR: 90° SAFETY OR BAD-ASS-ST / BAD-CASS-ST SHORT THROW
- MULTI CALIBER MARKING FOR BUILD VERSATILITY
- FLARED, DEEP BEVELED MAGWELL
- EASY IN INSTALL SET SCREW BOLT CATCH PIN (PIN INCLUDED)
- CAPTURED TAKEDOWN PIN DETENT SPRING (SET SCREW INCLUDED)
- UPPER/LOWER RECEIVER TENSION SCREW (SCREW INCLUDED)
- INTEGRATED TRIGGER GUARD
- 100% MADE IN THE USA

ALSO AVAILABLE IN FDE CERAKOTE FINISH





# BAD556-LW

7075-T6 LIGHTWEIGHT BILLET RECEIVER SET

**\$549.00**

ALSO AVAILABLE IN FDE CERAKOTE FINISH

#### LOWER RECEIVER SPECIFICATIONS:

- PRECISION CNC FROM BILLET 7075-T6 AEROSPACE ALUMINUM
- PATENT PENDING LIGHTWEIGHT DESIGN
- LASER ENGRAVED LOGO
- MIL-A-8625F, TYPE III, CLASS 2, HARD ANODIZED FLAT BLACK FINISH
- COMPATIBLE WITH TDP/MIL STANDARD AR LOWER RECEIVER PARTS
- DIMENSIONAL ACCURACY INSPECTION
- ALL SHARP EDGES DE-BURRED SHARP BY HAND
- PICTOGRAPH SELECTOR MARKINGS PROPERLY MARKED FOR 90° SAFETY OR BAD-ASS-ST / BAD-CASS-ST SHORT THROW AMBIDEXTROUS SAFETY SELECTORS
- RECEIVER SAFETY SELECTOR HOLE & INTERNAL WALL MACHINED WITH RELIEF CUT FOR BATTLE ARMS DEVELOPMENT "SHORT-THROW / REVERSIBLE" AMBIDEXTROUS SAFETY SELECTORS
- MULTI CALIBER MARKING FOR BUILD VERSATILITY
- FLARED, DEEP BEVELED MAGWELL
- EASY IN INSTALL SET SCREW BOLT CATCH PIN (PIN INCLUDED)
- CAPTURED TAKEDOWN PIN DETENT SPRING (SET SCREW INCLUDED)

- UPPER/LOWER RECEIVER TENSION SCREW (SCREW INCLUDED)
- INTEGRATED TRIGGER GUARD
- ALL COMPONENTS, MATERIAL, AND PACKAGING MADE IN THE USA
- WEIGHT: 6.84 OZ

#### UPPER RECEIVER SPECIFICATIONS:

- PRECISION CNC FROM BILLET 7075-T6 AEROSPACE ALUMINUM
- PATENT PENDING LIGHTWEIGHT DESIGN
- M4 FEED RAMP
- MACHINED T-MARKS
- LASER ENGRAVED LOGO
- MIL-A-8625F, TYPE III, CLASS 2, HARD ANODIZED FLAT BLACK FINISH
- COMPATIBLE WITH TDP/MIL STANDARD AR UPPER RECEIVER PARTS
- ALL COMPONENTS, MATERIAL, AND PACKAGING MADE IN THE USA
- WEIGHT: 6.28 OZ
- NEW GEN 2! LIGHTER WEIGHT (6.32 OZ TO 6.28 OZ). COMPATIBLE WITH FOR-TIS REV II RAIL (WITH INDEXING TABS)



# BAD 556 BUILDER SETS

LIGHTWEIGHT RECEIVER SET



# BAD-GS



## BAD-GS BILLET DEDICATED GLOCK

9MM AR LOWER RECEIVER

\$ 289.<sup>00</sup>

BATTLEARMS™ GLOCK MAGAZINE AR LOWER - SMALL FRAME GLOCK CALIBERS

- ACCEPTS GLOCK 9MM MAGAZINES.
- MADE FROM BILLET ALUMINUM.
- NO LAST ROUND BOLT HOLD OPEN
- LIGHTWEIGHT DESIGN.





# BAD-PDW | \$975.00

MONOLITHIC PDW LOWER RECEIVER + VERT STOCK SYSTEM

- MONOLITHIC DESIGN
- SELF-CONTAINED ULTRA COMPACT BUFFER SYSTEM
- COMPATIBLE WITH MILSPEC M16 BOLT CARRIER
- 4.75" LONG FULLY COLLAPSED, 8.75" LONG FULLY EXTENDED
- BUILT-IN AMBIDEXTROUS BOLT RELEASE AND MAGAZINE RELEASE





# STOCKS



\$39.95

# AR15RE-MIL-6C MIL-SPEC 6 POSITION CARBINE RECEIVER EXTENSION

NOT INCLUDED: BUFFER, BUFFER SPRING, CASTLE NUT, AND END PLATE

- MIL-SPEC CARBINE LENGTH RECEIVER EXTENSION / BUFFER TUBE
- 6 POSITIONS
- PRECISION CNC FROM 7075T6 AIRCRAFT GRADE ALUMINUM IMPACT FORGING
- MILSPEC TYPE III CLASS 2 HARD ANODIZED BLACK
- MADE IN THE USA

WHY NOT MAKE IT A COMBO?



# BAD-LBS-MIL | \$75.95 LIGHTWEIGHT BUTT STOCK

BUILT FOR THE MIL-SPEC BUFFER TUBE

- PRECISION CNC FROM 7075T6 AIRCRAFT GRADE ALUMINUM
- MILSPEC TYPE III CLASS 2 HARD ANODIZED BLACK
- BUILT-IN NON-ROTATING QD
- LIGHTWEIGHT 3 OUNCES (STOCK ONLY, 3.17 OZ WITH STEEL SCREW)
- MIL-SPEC CARBINE LENGTH BUFFER TUBE COMPATIBLE

# ONLY 3 OUNCES

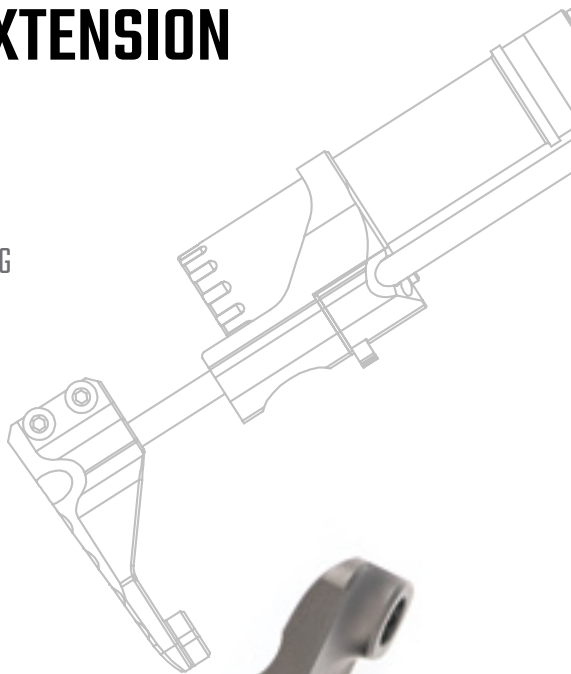

# HOME OF THE SABERTUBE®

# SABERTUBE™

LIGHTWEIGHT RECEIVER EXTENSION



**NEW!**  
**ULTRA COMPACT PISTOL LENGTH** | \$225.00  
WITH QD END PLATE + BAD-LBS

- COMPATIBLE WITH MIL-SPEC M16 BOLT CARRIER
- OVERALL LENGTH FROM REAR OF RECEIVER TO END OF BUTTSTOCK = 4.75"

- COMPATIBLE WITH THE ULTRA COMPACT VERT® BUFFER SYSTEM ONLY
- PRECISION CNC FROM BILLET 6061 AIRCRAFT GRADE ALUMINUM
- MILSPEC TYPE III CLASS 2 HARD ANODIZED BLACK
- UNIQUE, LIGHTWEIGHT AND FUNCTIONAL DIMPLED PATTERN DESIGN
- FITS MIL-SPEC COMPATIBLE AR15 LOWER RECEIVERS.
- LIGHTWEIGHT DESIGN ELIMINATED THE NEED FOR CASTLE NUT

**PISTOL LENGTH** | \$119.00  
WITH QD END PLATE

- COMPATIBLE WITH ALL STANDARD AR-15 LOWER RECEIVERS / NO NEED FOR CAPTIVE REAR TAKEDOWN PIN DETENT SPRING
- OVERALL LENGTH FROM REAR OF RECEIVER TO END OF BUTTSTOCK = 6.75"

**MID LENGTH** | \$199.95  
WITH QD END PLATE + BAD-LBS

- FITS LOWER RECEIVERS WITH CAPTIVE REAR TAKEDOWN PIN DETENT SPRING (I.E. BAD556-LW LOWER RECEIVER)
- OVERALL LENGTH FROM REAR OF RECEIVER TO END OF BUTTSTOCK = 8.25"

**RIFLE LENGTH** | \$215.00  
WITH QD END PLATE + BAD-LBS

- COMPATIBLE WITH ALL STANDARD AR-15 LOWER RECEIVERS / NO NEED FOR CAPTIVE REAR TAKEDOWN PIN DETENT SPRING
- OVERALL LENGTH FROM REAR OF RECEIVER TO END OF BUTTSTOCK = 9.25"



RIFLE LENGTH

9.25"

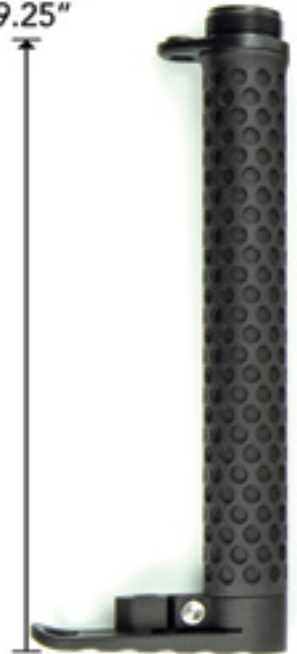

MID LENGTH

8.25"



PISTOL LENGTH

6.75"

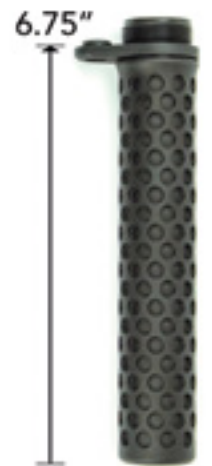

ULTRA COMPACT PISTOL LENGTH

4.75"



## SABERTUBE PISTOL TAILHOOK COMBO



\$239.00

### PACKAGE INCLUDES:

- (1) SABERTUBE® RECEIVER EXTENSION/BUFFER TUBE
- (1) QD END PLATE
- (1) VC-3 THREAD LOCKER
- (1) GEAR HEAD WORKS TAILHOOK MOD 1 (ALUMINUM - BLACK)

# VERT STOCK SYSTEM



## BAD-CSS VERT STOCK SYSTEM

\$425.00 

- COMPATIBLE WITH MILSPEC M16 BOLT CARRIER
- 4.75" LONG FULLY COLLAPSED, 8.75" LONG FULLY EXTENDED
- 4 LOCKING POSITIONS (LOCKS IN BOTH DIRECTIONS)
- CONTINUOUS CHEEK REST (CARBON FIBER-STYLED KYDEX)
- PRECISION CNC FROM AIRCRAFT GRADE ALUMINUM & S7 TOOL STEEL
- MILSPEC TYPE III CLASS 2 HARD ANODIZED BLACK
- 2 BUILT-IN NON-ROTATING QD POINTS
- ONLY 19.5 OUNCES (COMPLETE STOCK SYSTEM WITH BUFFER & SPRINGS)
- MADE IN U.S.A.



CONTINUOUS CHEEKREST | LIGHTWEIGHT DESIGN (19.5 OZ) | STANDARD BCG COMPATIBLE



# HANDGUN PARTS

# GLOCK ACCESSORIES

## BATTLEARMS™ GLOCK MAGAZINE BASEPLATE 9/40/357SIG

\$35.00

AVAILABLE IN  
**5**  
COLORS

BLACK

CLEAR

RED

FDE

GOLD



### BACKPLATE



## BATTLEARMS™ MAGWELL GLOCK 17/22/31 BATTLEARMS™ MAGWELL GLOCK 19/23/32

\$110.00



BATTLEARMS™ ENHANCED CARRY MAG-WELL IS DESIGNED FOR EVERYDAY CARRY, WITH BENEFITS FOR THE PROFESSIONAL SHOOTER AS WELL.

SLIM PROFILE TO HELP WITH CONCEAL CARRY, BUT IS FLARED ENOUGH TO PROVIDE BENEFITS TO GRIP AND RELOADING. THIS MODEL EASILY ACCEPTS THE FACTORY GLOCK BACKSTRAPS PROVIDED WITH YOUR PISTOL WITH NO MODIFICATION REQUIRED. MADE FROM PRECISION MACHINED, HIGH-GRADE BILLET ALUMINUM SABERTUBE® DIMPLE PATTERN DESIGN. MADE IN THE USA.

**\*\*NOTE: FITS GLOCK GEN 1-4 AND POLYMER 80 FRAMES. DOES NOT WORK ON GEN 5 AT THIS TIME.**



CUSTOM SHOP



# 11 CUSTOM CERAKOTE DESIGNS

BATTLE ARMS DEVELOPMENT,  
CUSTOM CERAKOTE SHOP

BLACK CAMO

DESERT RAGE CAMO

GREEN CAMO

MULTI CAMO

STAR WARS\*  
BOBA FETT  
VADER

300™ SPARTAN\*  
CAPTAIN AMERICA\*  
IRON MAN\*

\*COLOR SCHEMES ARE INSPIRED BY THESE MOVIES.



# BattleArms CUSTOM SHOP



## BATTLE ARMS DEVELOPMENT CUSTOM LASER ENGRAVED MAGAZINES

- CALIBER DESIGNATIONS - SHOW OFF YOUR NEW CALIBER
- PATRIOTIC DESIGNS
- TRIBUTES
- LAW ENFORCEMENT BADGES
- MILITARY LOGOS/RANKS
- ANYTHING YOU CAN IMAGINE.

### TRADEMARKED LOGOS

WE TAKE NO RESPONSIBILITY IN OWNERSHIP OR USE OF ANY TRADEMARKED OR COPYRIGHTED LOGOS. THE CUSTOMER IS RESPONSIBLE FOR ACQUIRING ANY AND ALL PERMISSIONS AND OR USAGE RIGHTS OF ANY LOGO.

### OPTIONS

WE KEEP THE MOST POPULAR VARIANTS IN STOCK AS WE ARE ABLE, SELECT FROM THE VARIOUS OPTIONS.

### GRAPHIC REQUIREMENTS:

COLOR VS. GRAYSCALE VS. BLACK AND WHITE - THE ENGRAVING PROCESS ONLY ENGRAVES IN 2 BIT BLACK AND WHITE. FOR THE CLEANEST AND BEST LOOKING ENGRAVINGS, WE RECOMMEND USING BLACK AND WHITE IMAGES ONLY. BLACK AND WHITE IMAGES HAVE NO GRAY, SHADING, SHADOW, FADING, OR OTHER EFFECTS. IF YOU ARE STILL UNSURE, THE IMAGE BELOW IS AN EXAMPLE OF PURE BLACK AND WHITE. WE CAN USE GRAYSCALE IMAGES, BUT THE DETAIL YOU SEE ON YOUR COMPUTER SCREEN GENERALLY DOESN'T FULLY TRANSLATE TO THE ENGRAVING.



RESOLUTION - IF YOUR IMAGE IS GRAINY AND PIXILATED, YOUR ENGRAVING WILL PROBABLY LOOK WORSE. THE MORE DETAIL IN YOUR IMAGE, THE BETTER THE IMAGE WE PREFER IN ORDER TO GET A GOOD CLEAN CAPTURE TO TRANSFER TO OUR ENGRAVING MACHINE. ALSO KEEP IN MIND THE SIZE OF THE DUST COVER, IF WE TRY TO TAKE A HIGHLY DETAILED IMAGE AND SHRINK IT DOWN TO 1/2" TALL, WE WILL LOSE A LOT OF THE DETAIL. A SIMPLE TEST IF YOU ARE ABLE IS TO TAKE YOUR IMAGE AND SHRINK IT DOWN TO 1/2" TALL AND PRINT IT OUT ON YOUR PRINTER, IF YOU CAN MAKE IT OUT, IT WILL PROBABLY BE OK.

# LASER ENGRAVING



M1A / M14 / M1 GARAND

## BAD-T4 M14/M1A & SEI GLFS WRENCH

\$35.00

THE BAD-T4 IS A FIVE (5) FUNCTION, DOUBLE-ENDED WRENCH. ON ONE END, IT IS A GAS CYLINDER LOCK WRENCH FOR THE M14 / M1A RIFLES AND ON THE OTHER END, IT IS A WRENCH FOR THE SEI GAS LOCK FRONT SIGHT.



## BAD-T3 M14/M1A & M1 GARAND GAS CYLINDER LOCK WRENCH

\$35.00

THE BAD-T3 IS A FIVE (5) FUNCTION, DOUBLE-ENDED GAS CYLINDER LOCK WRENCH FOR THE M14 / M1A AND THE M1 GARAND RIFLES. 100% MADE IN THE U.S.A., OUT OF HIGH QUALITY 3/8" THICK AIRCRAFT GRADE 7075-T6 ALUMINUM AND ANODIZED IN OD GREEN.

GEAR / SWAG / PROPOGANDA



**BAD INC ROUND PVC PATCH**  
BATTLE ARMS DEVELOPMENT - 3" DIA. PVC PATCH  
- VELCRO BACKED \$4.95



**BAD-PATCH-C**  
BATTLE ARMS DEVELOPMENT - 3" DIA. PATCH WITH NEW ROUND  
BATTLE ARMS LOGO - VELCRO BACKED \$5.00



**BAD-PATCH-T**  
BATTLE ARMS DEVELOPMENT - 4" TRIANGULAR PATCH  
- VELCRO BACKED \$6.50



**BAD-BOMB-MAGNET**  
BATTLE ARMS DEVELOPMENT - FLAMING BOMB MAGNET  
DECAL - APPROXIMATELY 2" X 4  
\$8.00



**BAD-MOUSE-PAD**  
7.5" X 8", 1/4" THICK, THIS MOUSE PAD DEPICTS THE BAD-  
CASS-SA-ST (SHORT THROW) IN ITS 45 DEGREE FIRE PO-  
SITION. BASE: NATURAL RUBBER TOP: ULTRA-SMOOTH  
POLYESTER CLOTH  
\$12.00



**BATTLE ARMS LOGO T-SHIRT**  
COTTON T-SHIRT (FRONT AND BACK)  
CHOICE OF OD GREEN AND GREY M, L, XL, XXL  
AVAILABLE IN BOTH MEN AND WOMEN STYLES  
\$25.00



**BATTLE ARMS "B.A.D TO THE BONE™"**  
**LOGO T-SHIRT**  
B.A.D TO THE BONE COTTON T-SHIRT (FRONT AND BACK)  
CHOICE OF OD GREEN AND BLACK. M, L, XL  
\$25.00



**BATTLE ARMS DEVELOPMENT**  
**- NON-STRUCTURED HAT**  
BATTLE ARMS DEVELOPMENT LOGO NON STRUCTURED  
EMBROIDERED HAT -KHAKI OR OD GREEN  
\$25.00

# LIGHTWEIGHT